



---

GUIDEBOOK TO ENJOYMENT OF  
YOUR KZRV  
RECREATIONAL VEHICLE

---

*SPORTSMEN CLASSIC*  
*SPREE ESCAPE*

THE PURPOSE OF THIS OWNER'S MANUAL IS TO PROVIDE THE MOST CURRENT INFORMATION AVAILABLE FOR YOUR RECREATIONAL VEHICLE ABOUT USAGE AND OPERATION.

ALSO MINOR MAINTENANCE AND CRITICAL SAFETY WARNINGS ARE INCLUDED ,MUST BE READ, UNDERSTOOD AND OBEYED.

ADDITIONAL MAINTENANCE INFORMATION IS FOUND IN THE "MAINTENANCE MANUAL" SUPPLIED WITH YOUR RECREATIONAL VEHICLE. FAILURE TO PROVIDE CARE FOR YOUR COACH WILL RESULT IN LOSS OF WARRANTY COVERAGE.

ADDITIONAL MANUALS MAY BE SUPPLIED AND AVAILABLE BY THE MANUFACTURER OF THE COMPONENT AND/OR APPLIANCE. SEE THE INFORMATION PACKET IN YOUR COACH.

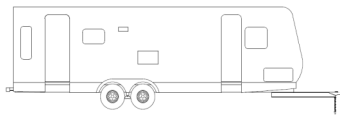

Conventional Travel Trailer

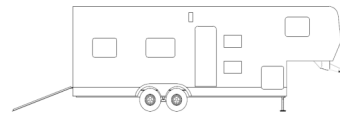

Travel Trailer Toy Hauler

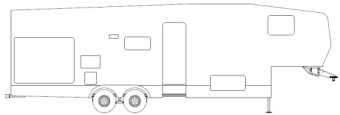

Fifth Wheel

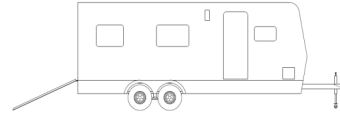

Fifth Wheel Toy Hauler

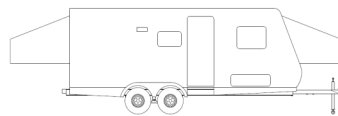

Hybrid Travel Trailer

**KZRV**  
**“BUILDING QUALITY AND FUN**  
**FOR OVER 40 YEARS”**

We congratulate you on your purchase of a KZRV, recreational vehicle. You have chosen a quality built RV which should provide you with many years of camping memories and fun.

The recreational vehicle you have purchased has been inspected by our trained inspectors and fully meets our high quality standards.

As the owner of a new KZRV, RV you can rest assured that we will do all we can to keep you a “happy camper”. Naturally, your selling dealership is always happy to help you with any questions you may have or service you may need. And should you need assistance when traveling, with over 250 KZRV, dealers nationwide, assistance is usually just minutes away.



**KZRV**  
0985 N 900 W  
Shipshewana, IN 46565

# TABLE OF CONTENTS

<b>Chapter 1 – Introduction to RV Ownership</b> .....	<b>1</b>
Safety Considerations .....	2
Reporting Safety Defects .....	2
Safety When Emergency Stopping .....	3
Additional Safety Considerations .....	3
Condensation .....	4
<b>Chapter 2 – Service Procedures</b> .....	<b>5</b>
Basic Service Procedures .....	5
Dealer .....	6
Factory .....	6
Parts .....	6
Owner’s Responsibility .....	6
Towable Limited Warranty .....	8
<b>Chapter 3 – Using Your RV</b> .....	<b>10</b>
Equipment .....	10
Tow Vehicle .....	10
Hitches – Travel Trailer .....	10
Hitch Height Specifications – Travel Trailer .....	11
Hook-Up (Travel Trailer) .....	11
The Safety Chain (Travel Trailer) .....	12
Traveling .....	12
Weights .....	12
Loading the Trailer—Distribution .....	13
Towing .....	14
Tires .....	15
Wheel lugs .....	17
Brakes .....	17
Breakaway Switch .....	18
Setting Up and Using Your Recreational Vehicle .....	18
General Detector Information .....	20
Propane Detector .....	20
Smoke Alarm .....	23
Fire Extinguisher .....	24
Windows .....	24
Steps .....	24
Doors .....	24
TV Antennas (Standard Roof Mount) .....	25
Slide-outs .....	26
Toy Hauler Group .....	27
Fuel In Cargo Area .....	29
<b>Chapter 4 – Systems</b> .....	<b>30</b>
Water and Drainage Plumbing .....	30

Tanks.....	30
Filling Fresh Water System.....	30
12-Volt Demand Pump .....	31
Faucets.....	31
Bath and Shower .....	32
Sanitizing and Filling the Potable Water System.....	32
Drainage (Fresh Water).....	33
Sanitation System.....	33
Toilets.....	34
Vents.....	35
Holding Tanks .....	35
Draining the Tanks .....	36
Maintenance for Holding Tanks .....	37
Winterizing Your Recreational Vehicle .....	37
Propane Fuel System.....	39
Propane Container.....	39
Servicing and Filling Propane Containers .....	40
Installing Propane Containers .....	42
Regulator.....	43
High Pressure Hoses with Acme Connectors.....	44
Main Supply Hose – Low Pressure .....	44
Operation.....	45
Checking for Leaks .....	46
If You Smell Gas .....	46
Propane Gas Consumption .....	46
Electrical System.....	48
General Information .....	48
Changes and Modifications .....	48
Power Cord.....	48
Circuit Breakers and Box .....	48
GFCI Protection.....	50
12 Volt DC System .....	51
Converter.....	51
Auxiliary Battery.....	51
Circuit Breakers and Fuses.....	52
Exterior Lights and Connector (12V).....	53
Porch Lights.....	54
Brake Wiring.....	54
<b>Chapter 5 – Appliances.....</b>	<b>55</b>
Furnace.....	55
Operating Instructions.....	55
Cooking System.....	57
Operating Instructions.....	57
Water Heater.....	59
Winterizing Your Water Heater.....	60

Refrigerator.....	61
Leveling.....	61
Venting.....	61
Door Seal.....	61
Door Latch.....	62
Air Conditioning (Optional).....	62
Tent Assembly.....	63
Important Information on Your Tent.....	63
Cleaning Your Tent.....	64
Tent Shrinkage.....	65

## CHAPTER 1 INTRODUCTION TO RV OWNERSHIP

Welcome to the world of recreational vehicle travel. The purchase of your KZRV product allows you to enter this type of camping and leisure travel. Your coach has been designed and engineered to offer many comforts of home. KZ recreational vehicles are designed and constructed to be used as temporary living quarters for camping and travel uses. The coaches are not intended for hauling cargo except Toy Haulers. Then only within weight limits.

This owner's manual was prepared to assist you in understanding the proper use and operation of various containment systems, servicing and maintenance of component parts, and explanation of your warranty protection. If this is your first RV travel coach, you will want to acquaint yourself with all aspects and information found in this manual plus manuals supplied by component manufacturers.

These materials will reflect the most current information available for the user. Some components and items may not be in your coach as they may be options on different models.

Keep this owner's manual in your recreational vehicle for handy reference. Get to know your new vehicle and how it operates. You should carefully read and understand these instructions, as well as information supplied by the manufacturers of separately warranted products, since they contain important operating, safety, and maintenance instructions. If you have questions that are not adequately answered by this manual or other booklets, consult your dealer. If he cannot satisfactorily answer your questions, he will call our staff for additional information.

Every effort has been made to provide you with a safe, dependable product. Your vehicle complies with applicable requirements of Federal Motor Vehicle Safety Standards, State Regulations, Canadian Standards Associations (CSA) where applicable, and complies with requirements of ANSI Standard 1192, the nationally recognized "Standard for Recreational Vehicles – Installation of Plumbing, Heating and Electrical Systems." The Recreational Vehicle Industry Association (RVIA) and Canadian Standards Association (CSA) periodically inspect our production lines and assist us in maintaining strict compliance with installation and safety standards for those systems. **Your follow-up with periodic safety inspections and a program of preventive maintenance is important for the continuation of safe and trouble-free**

**operation.**

Camping is a great way to relax and enjoy the outdoors with your friends and family. Please remember to tread lightly on our beautiful land and leave only your footprints so that others may enjoy nature as much as you did.

**SAFETY CONSIDERATIONS**

The terms **NOTE**, **CAUTION**, **WARNING** and **DANGER** have specific meanings in this manual as well as component and vender manuals.

A **NOTE** provides additional information to make a step or procedure easier or clearer. Disregarding a **NOTE** could cause inconvenience, but would not be likely to cause damage or personal injury.

A **CAUTION** emphasizes areas where equipment damage could result. Disregarding a **CAUTION** could cause permanent mechanical damage. However, personal injury is unlikely.

A **WARNING** is giving notice to user that potential injuries may occur to a person from equipment and mechanical failure. Disregarding a **WARNING** may result in serious physical injury to occupant.

A **DANGER** alerts areas where safety measures **MUST** be strictly adhered to as such failures can be dangerous, causing serious injury and possible loss of life.

**Reporting Safety Defects**

If you believe that your vehicle has a defect which could cause a crash or could cause injury or death, you should immediately inform the National Highway Traffic Safety Administration (NHTSA) in addition to notifying KZRV.

If NHTSA in addition receives similar complaints, it may open an investigation, and if it finds that a safety defect exists in a group of vehicles, it may order a recall and remedy campaign. However, NHTSA cannot become involved in individual problems between you, your dealer or KZRV.

To contact NHTSA, you may either call the Auto Safety Hotline toll-free at 1-800-424-9393 or write to:

NHTSA  
US Department of Transportation  
Washington, DC 20590



You can also obtain other information about motor vehicle safety from the Hotline.

### **Safety When Emergency Stopping**

It is wise to carry road flags and/or triangular warning devices to be used when necessary. When pulling off a highway, use your four way hazard lights as warning flashers, even if only to change drivers. Pull off the road way completely if at all possible to change flat tires or any other emergency needs.

### **Additional Safety Considerations**

1. Sanitize the fresh water supply system periodically (see sanitizing instructions).
2. Keep water connection fittings from coming in contact with the ground or drain hose to reduce chance of contamination.
3. Enlist services of a qualified technician to fix gas or electrical appliances.
4. Always have a serviceable fire extinguisher placed in an easily accessible location.
5. Insure that tires are in good condition and properly inflated. Watch tire inflation closely. Under-inflated tires will overheat. Overheated tires are a potential hazard as they may throw rubber and cause a blow-out. Check the tire pressure before each trip while the tires are cold.
6. Check and tighten the wheel lugs regularly (every 50 miles when new until 200 miles are reached and then check the lugs every 500 miles).
7. Check the brakes in a safe area – not while traveling a busy highway.
8. Always block the trailer wheels solidly before unhitching.
9. Before leaving a camp area with a trailer in tow, insure:
  - a. The safety pin or locking lever is seated.
  - b. The breakaway wire is attached to the tow vehicle.
  - c. All jacks are raised so that they cannot touch the ground.
  - d. The 110-volt electrical cord is properly stored.
  - e. The safety chains are connected.
  - f. All interior lights are off.
10. Observe and obey the warning labels attached to your vehicle concerning propane, water, electricity and loading.
11. Extinguish all campfires before leaving your campsite.

## CONDENSATION

Where it comes from, what causes it, and various solutions.

### Causes:

- A. It occurs when warm moist air contacts a cold surface, such as rain touching a tent, awning fabric with people breathing warm moist air against it from inside due to normal breathing.
- B. When cooking food or taking a shower, warm moist air circulates thru out coach attaching itself to cooler surfaces, forming beads and running down wall or window
- C. Normal breathing will emit approximately 1/2 pint of moisture into the air per person, per day. The more occupants the greater quantity of condensation you may find.

### Solutions:

- 1. When taking a shower, open bath roof vent approximately 1/2 inch allowing moisture to escape.
- 2. Use the power vent over range when cooking.
- 3. If condensation is found in cabinet or closets, open door slightly to equalize temperature and provide ventilation.
- 4. Opening windows and roof vents, when possible, allowing warm moist air to escape is the best way to reduce condensation.
- 5. Under extreme conditions, you may need to use a dehumidifier to remove moist air conditions.

In camping, models which have tents or fabric bunk areas, it is even more important to avoid condensation drops from roof area.

Opening the tent window at the person's head will allow air to flow across roof reducing or avoiding condensation.

Uncontrolled condensation can cause dampness, mildew, etc., inside your recreational vehicle. Be sure to make strong efforts to control condensation.



## **CHAPTER 2 SERVICE PROCEDURES**

### **BASIC SERVICE PROCEDURES**

KZRV has a strong interest in maintaining top quality customer relations with owners. By producing high quality products, we want to assure our customers of our support with parts and service availability. Our dealer network is the first choice to serve and supply your needs for your recreational vehicle. Our authorized dealers will pleasantly assist in providing service maintenance needs plus parts, options, and information concerning your recreational vehicle.

Should you experience a problem with service availability, please follow the steps in the order listed below.

1. Contact your selling dealer's service department for an appointment. Describe to the best of your knowledge the nature of the problem. Please keep appointments to establish a good, workable relationship.
2. Contact the owner or general manager of the dealership should the initial attempt fail with the service department.

3. Contact:           Customer Relations Department  
                          KZRV  
                          0985 N 900 W  
                          Shipshewana, IN 46565

Phone: (866)472-5460  
Hours: (8am-5pm E.S.T.)

E-mail: [kz@kz-rv.com](mailto:kz@kz-rv.com)  
Website: <http://www.kz-rv.com>

Give all the above information as requested along with the serial number of the coach in question. We will make every attempt to resolve your problem.

Please bear in mind that most problems arise from misunderstandings concerning warranty coverage and service. In most instances, you will be referred to the dealer level and your concerns will be resolved with the dealer's facilities and personnel.

## **Dealer**

Your authorized KZRV dealer has performed a PDI (pre-delivery inspection) on your recreational vehicle. Since your dealer is authorized to sell KZRV products, he is also there to supply parts, optional equipment, and provide service repairs, warranty or otherwise as needed.

First choice for warranty repairs is your selling dealer. Other dealers can be used, however, prior approval is required.

Some recreational vehicle dealers may be authorized service centers for certain manufacturers of products warranted separately. Check with your dealer before contacting anyone else to reduce delays. If the dealer is not an authorized service center for the product in question, he can assist you in obtaining authorized service.

## **Factory**

Service repairs can be performed at the manufacturing facility at Shipshewana, Indiana. Should your KZRV product be in need of major repairs and your dealer recommends factory repairs, please follow the steps listed below for such work.

1. Your dealer **must** make an appointment with service personnel at the factory PRIOR to your arrival.
2. Any freight costs, as listed on warranty coverage, are the responsibility of the owner as listed in the warranty coverage schedule.

## **Parts**

Stocking of parts varies from dealer to dealer. Any authorized dealer can order any required part to be shipped to his dealership or have the part "drop-shipped" to your residence. All parts are obtained through authorized KZRV dealers only.

## **Owner's Responsibility**

When owning and using a recreational vehicle, it is important to perform regular and normal maintenance to prevent undesired deterioration of your coach. Weather elements play an important function on sealants and other components requiring normal maintenance.

As an owner and operator, it is your responsibility and obligation to inspect and return your coach to an authorized dealer for repairs as required. Your authorized selling dealer is always your first choice and he certainly has continued interest in your satisfaction. As your manufacturer, we recommend that inspection and service be performed by your selling dealership.

If you are traveling and are unable to locate an authorized KZRV dealer, or an authorized dealer for the component needing service, please call our customer service office at (866)472-5460. Service at a non-authorized dealer MUST have prior authorization. You will be asked to return any mechanical parts replaced before reimbursement consideration is made. Unauthorized or improper repairs may void the warranty of that component. Always keep your owner's manual in your coach along with a copy of your warranty registration with you when traveling.

# **CLASSIC - ESCAPE**

## **TOWABLE LIMITED WARRANTY**

### **One Year Limited Warranty**

**SUMMARY OF WARRANTY:** KZRV warrants the structure of every Sportsmen Classic Travel trailer purchased from an authorized KZRV dealer to the first retail consumer for a period of one (1) year to be free from substantial defects in materials and workmanship when used for its intended purpose. This Towable Limited Warranty ["TLW"] does not apply to towable recreational vehicles purchased from any source other than an authorized KZRV dealer. The warranty period begins on the date of purchase or the date the unit is first placed in service, whichever is earlier. For purposes of this TLW, the term "structure" includes the interior and exterior sidewalls, floor, roof, and frame.

**EXCLUSIONS FROM WARRANTY:** Excluded from coverage under the TLW are: (1) items added, changed, or modified after the unit left the possession of KZRV; (2) units used for any commercial purpose; (3) units used for full-time residential use or more than occasional recreational use; (4) wear and tear caused by normal usage by the consumer, including but not limited to fading or discoloration of soft goods [e.g., tents, upholstery, drapes, carpet, vinyl, screens, cushions, and mattresses], fading or discoloration of exterior or fiberglass components, tears, punctures, soiling, mildew, mold, and the effects of moisture condensation inside the unit; (5) the effects of alteration, tampering, mishandling, neglect, abuse, misuse, weather, acts of nature, acts of God, or corrosive atmospheres that promote rusting, oxidation, or pitting; (6) minor imperfections that do not interfere or affect the suitability of the unit for its intended use; (7) the effects of consumer's or transferee's failure to perform normal and routine maintenance [e.g., inspections, lubrication, adjustments, tightening of screws and bolts, tightening of lug nuts and wheels, sealing, rotating, cleaning, or other damages resulting from failing to follow the maintenance schedule and procedures in the owners manual; (8) damages resulting from misalignment or adjustments to axles or spindles caused by improper maintenance, modification, loading, unloading, road hazards, road defects, off road travel, or tire failures; (9) damages caused by the negligent or intentional use or misuse of the unit by the consumer or transferee, including but not limited to occurrences while towing the unit; (10) loss or damage caused by a person or business as a result of transporting the unit after sale to the consumer, delivering the unit, or parking the unit; (11) loss or damage to the plumbing system caused by freezing; (12) claims for personal injuries of any type; (13) costs of transportation of the unit for repairs; and (14) components that are warranted separately by another manufacturer [the warranty provided by a component manufacturer is the sole responsibility of that manufacturer, and KZRV does not warrant those components. Please refer to the warranties issued by the component manufacturers for the terms and conditions of such warranties].

**TO OBTAIN WARRANTY SERVICE:** Warranty service may be performed only at KZRV, or at KZRV authorized dealers and service centers. Contact KZRV for a list of authorized dealers and service centers. REPAIRS OR REPLACEMENTS BY UNAUTHORIZED DEALERS OR SERVICE CENTERS WILL VOID THIS TLW. If the consumer believes that a claimed defect is covered by this TLW, contact must be made with an authorized dealer or service center WITHIN THE WARRANTY PERIOD. Sufficient information must be given to attempt to resolve the claimed problem. Should KZRV determine that repair or replacement is appropriate, the consumer must deliver the unit to the dealer or service center as directed. Delivery shall occur no later than thirty (30) days after the authorization for repair or replacement. Do not deliver your unit to KZRV, an authorized dealer, or service center without prior authorization. All costs incurred by the consumer for transportation for warranty service shall be the sole responsibility of the consumer. The dealer or service center shall repair or replace any warranted defect within a reasonable time, but no later than ninety (90) days after delivery by the consumer. Should the unit not be repaired or replaced within said period of time, then the consumer must contact KZRV by CERTIFIED MAIL with a written description of the claimed warranted defect and the efforts to remedy it. FAILURE TO SO NOTIFY KZRV IN THIS REGARD SHALL RENDER THIS TLW VOID AS TO THE CLAIMED DEFECT. After receipt of such notice, KZRV shall repair or replace such warranted defect within a reasonable time, but not later than ninety (90) days after delivery by the consumer. The scheduling of warranty work at an authorized dealer or service center is not controlled by KZRV and delays may be experienced. KZRV is not responsible for loss of use of the unit, expenses for fuel, telephone, food, lodging, travel, loss of income or revenue, or loss of or damage to personal property.

**DISCLAIMER AND LIMITATIONS OF WARRANTIES:** NEITHER KZRV NOR ITS DEALERS SHALL BE LIABLE FOR INCIDENTAL, CONSEQUENTIAL, INDIRECT, SPECIAL, OR PUNITIVE DAMAGES OF ANY KIND OR ANY OTHER FINANCIAL LOSS ARISING OUT OF OR IN CONNECTION WITH THE SALE OR USE OF THIS PRODUCT, WHETHER BASED IN CONTRACT, TORT, STRICT LIABILITY, EQUITY, OR ANY OTHER THEORY, EVEN IF KZRV HAS BEEN ADVISED OF THE POSSIBILITY OF SUCH DAMAGES. KZRV'S ENTIRE LIABILITY SHALL BE LIMITED TO REPAIR OR REPLACEMENT, AT KZRV'S SOLE OPTION.

THE UNITED NATIONS CONVENTION ON CONTRACTS FOR THE INTERNATIONAL SALE OF GOODS IS

HEREBY EXCLUDED IN ITS ENTIRETY FROM APPLICATION TO THIS TLW. THIS TLW, AND THE REMEDIES HEREUNDER, ARE EXCLUSIVE AND IN LIEU OF ALL OTHER WARRANTIES, EXPRESS OR IMPLIED, INCLUDING WARRANTIES OF MERCHANTABILITY, FITNESS FOR A PARTICULAR PURPOSE, CORRESPONDENCE WITH DESCRIPTION, AND NON-INFRINGEMENT, ALL OF WHICH ARE EXPRESSLY DISCLAIMED BY KZRV. THIS TLW GIVES YOU SPECIFIC LEGAL RIGHTS AND YOU MAY ALSO HAVE OTHER RIGHTS THAT VARY DEPENDING ON LOCAL LAW. SOME STATES LIMIT OR PROHIBIT LIMITATIONS OF WARRANTIES, SO THE ABOVE MAY NOT APPLY TO YOU. YOU SHOULD CONSULT A COMPETENT ATTORNEY FOR LEGAL ADVICE.

**MISCELLANEOUS:** No repair or replacement effected shall cause any extension or renewal of the warranty period. KZRV may make parts and/or design changes from time to time without notice and repairs or replacements may be made with new or different parts. KZRV reserves the right to make changes in the design or material of its products without incurring any obligation to incorporate such changes in any product previously manufactured. At KZRV's, sole option, any dispute concerning any warranted defect may be resolved through mediation or arbitration. This TLW shall be governed by the laws of the State of Indiana, and any legal action shall be brought only in the Circuit or Superior Court of LaGrange County, Indiana.

**ALTERNATIVE DISPUTE RESOLUTION:** The parties shall attempt in good faith to resolve any disputes by negotiations. If unsuccessful, KZRV may, in its sole discretion, elect to submit the matter to binding arbitration and, if such election is exercised, the consumer covenants and agrees that he, she, they, or it shall submit any such disputes to such binding arbitration. The arbitral body shall be either the American Arbitration Association or the National Arbitration Foundation, and the rules of the body chosen by KZRV shall govern except to the extent same are in conflict with the Indiana Uniform Arbitration Act, which shall govern. The arbitrator is expressly empowered to enter an award of default against any party in the event of: (a) the failure or refusal of such party to comply with any deadline fixed by the arbitrator; (b) the failure or refusal of such party to make timely payment of any fees, expenses, or other charges billed by the arbitrator; or (c) any other failure or refusal by such party to cooperate and participate in any aspect of the arbitration proceedings. The arbitrator will admit only relevant and reliable evidence at the hearing, but no particular rules of evidence are specified for use. The hearing shall be electronically recorded by an Indiana Notary Public or other officer authorized by Indiana law to administer oaths, and all witnesses who shall testify shall be sworn on oath to tell the truth. The arbitrator may award injunctive relief, interest, and attorney fees in an equitable amount based upon the degree to which the prevailing party prevails on the merits; however, the arbitrator is not empowered to award punitive or exemplary damages. All costs of the arbitration, including the recording thereof, shall be shared equally by the parties. The arbitration proceedings and award shall remain confidential, and no party may disclose to any person, except attorneys for the parties, any aspect of the proceedings.

**WARRANTY REGISTRATION AND CONTACT INFORMATION:** The warranty registrations for component parts should be completed and delivered in accordance with the instructions contained therein. The TLW registration must be completed and returned to KZRV within fifteen (15) days of delivery of the unit to the consumer. Failure to do so can void this TLW or cause delays in obtaining benefits. The TLW registration, and all inquiries, must be directed to: KZRV, L.P., Warranty Department, 0985 N 900W, Shipshewana, Indiana 46565, Telephone: (260) 768-4016.

**Model Number** \_\_\_\_\_ **V.I.N.** \_\_\_\_\_

**Dealer Information:**  
[ \_\_\_\_\_ ]

**Customer Information:**  
**Name:** \_\_\_\_\_  
**Address:** \_\_\_\_\_  
\_\_\_\_\_

**Phone:** \_\_\_\_\_

**I HEREBY ACKNOWLEDGE THAT I HAVE RECEIVED, READ, AND UNDERSTAND THIS TOWABLE LIMITED WARRANTY, AND THAT I HAVE INSPECTED THE UNIT AND FIND IT IN THE CONDITION REPRESENTED.**

Date: \_\_\_\_\_  
Purchaser

## CHAPTER 3 USING YOUR RV

In this chapter you will find three areas of useful information to assist you with correct **equipment**, **traveling**, and finally, actually **using your recreational vehicle**.

### EQUIPMENT

#### **Tow Vehicle**

Begin your camping experiences by obtaining a tow vehicle which will adequately transport your recreational vehicle to and from your chosen destinations. Your most important measuring tool is the GVWR, Gross Vehicle Weight Rating, to cross match the capability of your selected tow vehicle.

Most auto or truck manufacturers provide trailer towing guides for their products. Ask your local automotive dealer for a copy or call the factory's direct lines for information. Many tow vehicles, including mini-vans, have special towing package options available for small travel trailers. Tow vehicles with long wheel bases perform better than those with short wheel bases.

A second factor is GCWR, Gross Combined Weight Rating, which refers to the total weight of the tow vehicle and any vehicle in tow as a "combined" weight. This information, supplied by the tow vehicle manufacturer, is related to the capability of the tow vehicle.

The condition of the suspension in your tow vehicle is also an important factor. Make sure your tow vehicle is in good operating condition and follow the factory recommended maintenance guidelines. It will affect your towing performance.

#### **Hitches – Travel Trailer**

After obtaining your tow vehicle, it is very important to choose, and have installed, a correct hitch system with weight distributing bars to accommodate your coach if so required. This selection and installation should be done by a professional hitch service center, which may or may not be your selling dealer.

Weight distributing hitches apply leverage between the tow vehicle and trailer. This assists in equalizing the weight between vehicles, resulting in both vehicles traveling level.



Optional sway controls are also helpful with travel towing, especially long and heavy tongue weight coaches.



## CAUTION

Trailers with tandem axles need to travel as level as possible, avoiding different weights on each axle plus handling conditions.



## CAUTION

Using an oversized or undersized hitch can cause damage to the frame of your travel trailer or tow vehicle.

### Hitch Height Specifications – Travel Trailer

Due to axles being either straight or drop bars, the ball height will vary. To find the correct height for the ball hitch, set your trailer on a flat surface in level position. Measure from the inside of the ball socket to the ground, approximately 18 to 22 inches as shown, for correct spacing. You may wish to add 1 to 2 inch to this amount to compensate for sag of suspension of the tow vehicles when hooked to tow vehicles.



### Hook-Up (Travel Trailer)

Hooking up your travel trailer is not difficult and gets easier with practice. The following procedure will help you until you become more experienced.

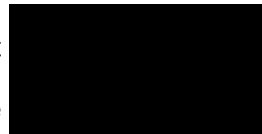

1. To raise the tongue of trailer above the hitch ball on hitch, turn the crank on the jack.
2. Open the coupler latch.
3. Back the tow vehicle into proper position.
4. Turn the crank on the jack to lower the coupler onto the ball hitch.
5. Close the coupler latch after completely seated. To secure coupler latch, it is recommended that you install a latch pin or a lock.
6. Install weight distributing bars (equalizer), when required, as recommended by hitch supplier.
7. Retract the tongue jack to its maximum height.

8. Attach the cable for the breakaway switch to the tow vehicle.
9. Attach safety chains as per your state laws.
10. Plug in your 12-volt, seven way electrical connector from the tow vehicle to the trailer connector.
11. Below are listed numerous items that should be inspected and tested before traveling:
  - All lights working on outside of coach.
  - Stabilizer jacks in retracted position.
  - Steps in retracted position.
  - Refrigerator door latched completely.
  - Loose items in secure position.
  - Test brakes for operation before entering roadway.

### **The Safety Chain (Travel Trailer)**

Safety chain requirements will vary from state to state. The chain supplied with your coach meets SAE requirements for maximum gross trailer weight.

1. Cross the left chain under the coupler and attach to the right mounting slot in the tow vehicle hitch head.
2. Now take right chain under the coupler and attach to left mounting slot in hitch head. Slack for each length should be the same but not more than necessary to permit the vehicle to turn at their minimum radius.



## **TRAVELING**

### **Weights**

For safety reasons and federal regulations **KZRV** desires to provide the most accurate weight specifications possible to our new owners. On the exterior left front corner of the coach you will find the Federal "Vehicle Identification Number" sticker. While required by the federal government, this tag supplies much information concerning your coach, such as: VIN number, date/month of manufacture, tire size rating, plus information about weights as described below.

Gross Axle Weight Rating (GAWR): is the value specified as the load carrying capacity of a single axle system, as measured at the

tire-ground interfaces. One of five components will determine this rating, tires, axle, springs, brakes, or wheels. One of these five is generally rated slightly less than the others.

Gross Vehicle Weight Rating (GVWR): is the maximum permissible weight of this trailer when fully loaded. It includes all weight at the trailer axle(s) and tongue or pin on Fifth Wheel. This includes ALL cargo, options and liquids.

MANUFACTURED BY/FABRIQUÉ KZRV DATE: 03/2012  
GVWR/PNEU: 2727 KG (6000 SHIP SHEWANA, IN  
GAWR (EACH AXLE) / PNBE (CHAQUE ESSIEU) 1591 KG (3500 LB) TIRE/PNEU ST205/75R14 C  
RIM/JANTE 14X5.5 JJ  
COLD INFL. PRESS. /PRESS. DE CONFL. À FROID 345 KPA (50 PSI/LPC)  
THIS VEHICLE CONFORMS TO ALL APPLICABLE U.S. FEDERAL MOTOR VEHICLE SAFETY STANDARDS IN EFFECT ON THE DATE OF MANUFACTURE SHOWN ABOVE. THIS VEHICLE CONFORMS TO ALL APPLICABLE STANDARDS PRESENTED UNDER THE CANADIAN MOTOR VEHICLE SAFETY REGULATIONS IN EFFECT ON THE DATE OF MANUFACTURE. - CE VÉHICULE EST CONFORME À TOUTES LES NORMES QUI LUI SONT APPLICABLES EN VERTU DU RÈGLEMENT SUR LA SÉCURITÉ DES VÉHICULES AUTOMOBILES DU CANADA EN VIGUEUR À LA DATE DE SA FABRICATION.  
V.I.N./N.I.V. 4E2TS242DC5036114 TYPE/TYPE DE VÉHICULE: TRAILER TRAVREM TRA

Unloaded Vehicle Weight (UVW): is the weight of this trailer as manufactured at the factory. It includes all weight at the trailer axle (s) and tongue or pin. If applicable, it also includes full generator fluids, including fuel, engine oil and coolants.

Cargo Carrying Capacity (CCC): is equal to the GVWR minus each of the following: UVW, full fresh (potable) water weight (including water heater, and full propane weight.

RECREATION VEHICLE TRAILER CARGO CARRYING CAPACITY  
V.I.N.: 4E2TS242DC5036114  
THE WEIGHT OF CARGO SHOULD NEVER EXCEED  
844 kg 1800 lbs  
CAUTION:  
A full load of water equals 143 kg or 315 lbs of cargo @ 1 kg/L (8.3 lb/gal)

On the inside of the front screen door there should be a small yellow sticker giving the owner correct information as to quantity of cargo this coach can carry. This allowable weight is calculated including factory installed options. It does NOT include any dealer installed items.

Don't forget water and propane. The less water you carry the more cargo you can add.

## Loading the Trailer—Distribution

Your recreational vehicle has been engineered to make maximum use of the available space for living and storage areas. The equipment and supplies you take along while traveling can be carried safely, provided the additional weight is distributed properly.

Proper weight distribution within your trailer is an important factor in safety and efficiency of your trailer brakes, hitching, and how your tow vehicle will pull the trailer. DO NOT put excess weight in the trunk only. Excessive weight in the trunk area tends to develop sway and “fishtailing” of the trailer.

Lightweight and bulky items such as paper products, bedding, clothing, etc., should be stored in overhead cabinets and closets. Heavy items such as cooking utensils should be placed in lower cabinets. Canned goods need to be in a pantry, if so equipped, or in lower cabinets. Also, heavy items should be secured to avoid shifting during travel.

A reasonable principle in loading your coach is for every two pounds of weight loaded in front of the axle, one pound of weight must be loaded behind the axle. Also remember, improper side-to-side Loading affects spring condition.

Excess weight behind the axle lightens the hitch weight and will tend to magnify any sway that may occur when passing trucks or when gusty winds are present. Uncalculated weight can and will effect road performance.

	<b>CAUTION</b>
<b>Any damage caused by improper loading or installing additional equipment is NOT covered by <b>KZRV</b> Limited Warranty.</b>	

## Towing

In towing your trailer or fifth wheel you need to recognize the extra weight behind your vehicle. Below is a list of things which you need to remember while traveling.

1. With the trailer attached you will have slower acceleration and will require more distance to stop.

2. Be sure you have enough area at corners when turning, as wider turns are necessary. Be sure to use your turn signals for your own safety and the safety of others.
3. In passing or changing lanes remember you will need a longer distance to pass.
4. Use your rearview mirrors frequently to observe your trailer and traffic conditions.
5. When being passed by a large truck or bus, be prepared for displaced air as it may cause you to sway slightly, especially travel trailers.
6. When climbing steep, long grades and again while descending, use lower gears even before it seems necessary. Use your brakes smoothly and evenly.
7. Remember to drive more slowly on wet and icy highways to keep control of your vehicle.

WARNING

The rear bumper on the frame of your recreational vehicle is NOT designed to carry over 100 pounds of weight. Installation of items exceeding 100 pounds, including bike racks, generators, cargo containers, etc. could cause metal fatigue and weld stress. Any such failures could damage your property and endanger vehicles following your camper during travel, which could result in an accident. The frame is NOT designed or built to tow any trailer.



**TIRE AND LOADING INFORMATION**  
**RENSEIGNEMENTS SUR LES PNEUS ET LE CHARGEMENT**

The weight of cargo should never exceed 844 kg or 1,860 lbs.  
 Le poids du chargement ne doit jamais dépasser 844 kg ou 1,860 lb.

TIRE / PNEU	SIZE / DIMENSIONS	COLD TIRE PRESSURE / PRESSION DES PNEUS A FROID	SEE OWNER'S MANUAL FOR ADDITIONAL INFORMATION / VOIR LE MANUEL DE L'USAGER POUR PLUS DE RENSEIGNEMENTS
FRONT / AVANT	ST205/75R14 C	341 KPA (50 PSI)	SEE OWNER'S MANUAL FOR ADDITIONAL INFORMATION VOIR LE MANUEL DE L'USAGER POUR PLUS DE RENSEIGNEMENTS
REAR / ARRIERE	ST205/75R14 C	341 KPA (50 PSI)	
SPARE / RESERVE	ST205/75R14 C	341 KPA (50 PSI)	

M180500051214



## CAUTION

It is recommended that the tire pressure be checked at the beginning of each journey, and at least once per week during travel to obtain the maximum life of the tires.

### **TIRES**

All KZRV coaches are equipped with appropriate tires as per size and weight. Tires are rated to carry the weight as per G.V.W.R. as listed. Tires are radial in design using components to offer excellent strength and mileage in all kinds of weather conditions.

Tires on your vehicle (s) are one of the most important components of the towing package. Without inflated tires you will be not be moving anywhere. Studies of tire safety show that maintaining proper tire pressure, observing tire and vehicle load limits ( not carrying more weight in your vehicle than your tires or vehicle can safely handle ), avoiding road hazards and inspecting tires for cuts, slashes, and other irregularities are the most important things you can do avoid tire failure, such as tread separation or blowout and flat tires. These actions along with other care and maintenance activities can also

- \* Improve vehicle handling
- \* Help protect you and others from avoidable breakdowns and accidents.
- : \* Improve fuel economy
- \* Increase the life of your tires.

### **HOW TO CHANGE A TIRE**

1. Place blocking under the main rail of frame with hydraulic jack on top of blocking in front spring hanger, ALWAYS on main rail.
2. Break lug nuts loose before raising coach .DO NOT remove nuts
3. Raise coach with jack until tire is off the ground.
4. Place additional blocking under frame for security support. Do not depend fully on jack.
5. Be sure coach is solid and will not move with tire and wheel off.
6. Remove lug nuts when tire is off the ground.
7. Place spare tire and wheel onto hub.
8. Reinstall lug nuts and tighten firmly.
9. Drop tire and wheel onto ground after removing supports
10. Now fully tighten and torque lug nuts at 90 to 120 foot pounds.
11. Place all equipment into coach or tow vehicle , blocking and jack.
12. Re-torque wheel after traveling 100 miles.

## Wheel Lugs

When the wheels are newly installed on your recreational vehicle, the lug nuts must be tightened numerous times because powder coat paint on the wheel is thick. You must re-torque lugs at 50 and 200 miles. A decal on wheel may require torque-ing sooner.

After your first trip, check the wheel lugs periodically for safety. The lug nuts should be tested in spring before first trip out, or extensive braking. Size nut is 13/16. **Over torque-ing will damage components, exceeding 150 foot pounds. Normally the nut fails first however the embossing on the can also be damaged and fail to keep tight.**

## BRAKES-ELECTRICAL

Electric brakes on your recreational vehicle are designed to work in conjunction with brakes on your tow vehicle. This means to have the best per brake performance on both systems, the trailer and tow vehicle must perform together. Any attempt to use either alone, will cause accelerated wear and damage on one of them.

A brake control must be installed in your tow vehicle, normally below your dash board to activate brakes. It must have 12-volt power to operate either by foot pedal or manually. Use foot pedal for general operation. Manual control is to be used only special situations, such as slow movement or icy road conditions.

Power from the battery is sent to the controller, the "switch" to provide the correct amount of current to brake assemblies on the coach. As you press harder on the pedal, the more current will flow, applying brakes more, increasing braking capability.

Keep the battery in tow vehicle and its charging system in good working order to ensure available energy when required.

Wiring to operate your brakes must be sized in both, suggesting 12 or 14 gauge minimum for your tow vehicle. Your coach has 14 gauge from front end to brakes. Brake assemblies are wired in parallel, never in series. Being parallel, there will be equal voltage and amperage at each brake assembly. The brake assembly on your unit is self-adjusting. When driving in forward motion they adjust at each stop, ensuring constant braking and being adjusted automatically.

### BREAK-A-WAY SWITCH

Each state has its own laws concerning this component. With a 12 volt battery on coach, power is supplied to switch. Should a disconnect happen, coach from tow vehicle, pin pulls out and brakes come on, preventing full separation of vehicles.

NEVER use this brake-a-way switch for a parking brake. High amp draw will cause heat on wiring and other components.

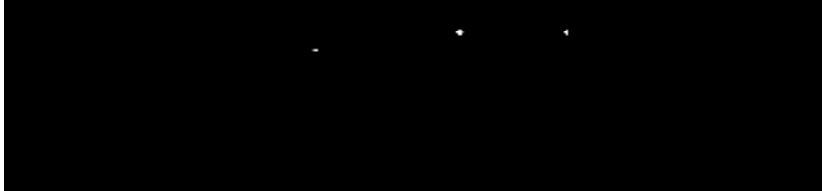

**SAFETY BREAK-AWAY SWITCH  
WILL NOT OPERATE**

Unless connected to a power source equivalent to or greater than an auto-motive type 12 volt, 12 amp hour wet-cell battery.

**Wheel lug nuts**

When the wheel are installed on your recreational vehicle, the lug must be tightened at 90 to 120 foot pounds of torque. With powder coat paint re-torquing will be required numerous times before they are fully seated. Re-torque wheels at 50 at 200 miles. A decal on wheel may require torquing more often,

**SETTING UP AND USING YOUR RECREATIONAL VEHICLE**

We recommend that you select a level or nearly level place for camping. There are two reasons to be level. First, all components in your camper, such as your water drainage system and refrigerator, are designed to operate in a level position. Second, it is more comfortable to live on the level. Should a level camp site not be available, use short 2 X 6 blocks of wood to the low side to a level position.

Before unhooking the trailer from the tow vehicle, be sure the tongue jack foot is in place and block the trailer wheels to prevent trailer from moving.

Before lowering the tongue jack, you may wish to place a wood block or hard support under the foot of the jack, unless you are on cement slab. This helps prevent jack from sinking into the dirt.



1. Release the weight distributing bars (if used).
2. Undo the safety pin or lock, then release the safety latch on the coupler.
3. Raise the coupler on the A-frame by turning the tongue jack until the ball is free.
4. Disconnect the 7-way wire connector, safety chains, and the breakaway cable.
5. Move the tow vehicle away as desired.
6. Lower the tongue jack until the coach is level.
7. Now lower the stabilizer jacks, two or four as equipped.

The use of stabilizer jacks on a recreational vehicle is a popular and useful option. They provide a reasonable amount of stability while using, occupying, and moving around in your camper. It is important to remember that stabilizer jacks are for support of the coach and are not designed to bear the weight of a recreational vehicle.

To operate the stabilizer jack, place crank onto the jack shaft and turn clockwise to lower until the frame begins to raise slightly. Equalize all four jacks for best support. You may need to adjust each jack two or three times.

To raise jack to upper travel position, turn counterclockwise until jack is seated in UP travel position.

Upon completing the setup of your coach you are now ready to make attachments to various facilities.

- ❖ Waste water hose connections.
- ❖ 110-Volt power cord electrical hookup.
- ❖ Turn on propane tanks and light pilot lights, if any, on appliances. Remember there may be air in your propane lines. Be sure to bleed them before planned usage.
- ❖ Open any windows and roof vents as desired for ventilation.

You may have additional accessories and options, such as an awning on the door side which need to be opened. Separate instructions are provided by the manufacturer of these components.



## CAUTION

**When preparing to depart or move, don't forget to reverse the procedure above. Remember, open roof vents, windows, or TV antennas left in UP position are subject to wind damage in transit.**

### **General Detector Information**

As you are confined in a RV which is much smaller than a standard house, you must realize safety detectors will be activated much sooner than in a residential house, due to there being much less air volume.

### **TEST SAFETY ALARM OPERATION AFTER VEHICLE HAS BEEN IN STORAGE, BEFORE EACH TRIP, AND AT LEAST ONCE PER WEEK DURING USE.**

Each listed detectors have its own manual and instructions sheet, providing more information for it's use and maintenance.

Life time if the detector ranges from five to ten years and will need to be replaced as per manufacturers instructions.

### **SAFETY DETECTORS**

#### **Combo Propane and Carbon Monoxide**

Any recreational vehicle which contains a propane fuel system with propane consuming appliances requires a propane leak detection device for safety protection. Currently this detector also serves as a carbon monoxide as a combination protection device. A converter or auxiliary battery is required to supply 12-volt DC energy to operate the leak detector.

A 3 amp in line fuse is located behind the detector and requires a screw driver to remove 2 screws to gain access to fuse. Test fuse before replacing any equipment. There is NO master cut-off switch for detector.

#### **OPERATION**

When the unit is first powered up, the CO sensor requires a ten (10) minute initial warm-up period to clean the sensor element and achieve stabilization. The GREEN LED indicator will flash on and off during the 10 minute warm-up period. The unit cannot go into a CO alarm during the warm-up period. To test your unit during the warm-up period, press the test button. See Test Procedure in this manual. After the warm-up period, the GREEN power ON indicator should glow continuously if the ON indicator light does not light, see the section, **Trouble-Shooting Guide**, in this manual for further information. **Do not attempt to fix it yourself.**

**Gas Alarm:** When you power the alarm, it has a warm-up period of approximately 1 minute. This unit cannot go into a gas alarm during the warm-up period. After 1 minute the alarm can detect propane.

**Simultaneous CO and Gas Alarms–** Because the risk of a propane gas disassembly is generally a more serious danger, your alarm unit gives the gas alarm a higher priority during simultaneous alarm condition.

If your unit generates alarms for both Gas and CO at the same time, the gas LED will flash red and the beeper will sound. The CO LED will be a solid Red until the CO is ventilated out of the RV, at which time the LED will return to the Green operational/safe color.

**Brownout Protection—** The unit can tolerate short power interruptions and brownouts where the circuit voltage drops as low as 1 VDC. If the brownout lasts too long, the unit will reset and operate as described above.

#### **LOW POWER OPERATION**

This alarm will operate normally down to 7 VDC. Below 7 VDC. Your alarm will not function.

#### **VISUAL AND AUDIBLE ALARM SIGNALS**

This SAFE-T-ALERT™ CO/Propane Gas Alarm is designed to be easy-to-operate. The alarm has two indicator lights that display a specific color for each monitored condition. There also is a matching sound pattern for alarm conditions.

#### **CO ALARM**

The Red CO LED will flash and the alarm will sound 4 “BEEPS” then silent for 5 seconds. These signals indicates that the CO level is over 35 ppm. **IMMEDIATE ACTION IS REQUIRED.** See **Procedures To Take During An Alarm.** This cycle will continue until the TEST/Mute button on the front of alarm is pressed. Ventilate the RV. The RED light will stay ON until the CO has cleared, or the alarm will reactivate in approximately 6 minutes if the CO is still present. DO NOT RE-ENTER THE RV. This alarm will return to normal operation after the RV’s properly ventilated.

#### **PROPANE GAS ALARM**

The RED LED will flash and the alarm will sound a steady tone whenever a dangerous level of propane or butane gas is detected. **IMMEDIATE ACTION IS REQUIRED.** See **Procedures Take During A Gas Alarm.** The detector will continue to alarm until

the Test/Mute switch on the front of the alarm is pressed. Ventilate the RV. The RED Gas LED will continue to flash until the gas has cleared, or the gas alarm will reactivate in approximately 5 minutes if the gas is still present. **DO NOT RE-ENTER THE RV.** This alarm will return to normal operation after the RV is properly ventilated.

**MALFUNCTION/SERVICE SIGNAL.** If any malfunction is detected, the Gas LED will remain off and the Operational/CO LED will alternate Red/Green and the alarm will sound once every 15 seconds. Press the Test/Mute button. If the Test/Mute button does not clear signals, check the battery voltage. **If the battery voltage is not low and the unit will not return to normal operation, immediately remove the alarm and return for service or warranty replacement.** See the warranty section in this manual.

<u>OPERATION</u>	<u>AUDIBLE SIGNAL</u>	<u>VISUAL SIGNAL</u>
NORMAL	NONE	STEADY GREEN
CO ALARM	4"BEEPS" 5 SECONDS OFF	STEADY RED
PROPANE ALARM	CONSTANT	FLASHING RED
ALARM MALFUNCTION	"BEEP" EVERY 30 SECONDS	ALTERNATING RED/GREEN
END OF LIFE	" BEEP EVERY" 30 seconds	RED RED GREEN GREEN FLASHING

This alarm is designed to detect CO and Propane. It is NOT designed to detect smoke

#### **WHAT IS CARBON MONOXIDE?**

Carbon Monoxide (CO) is a highly poisonous gas which is released when fuels are burnt. It is invisible, has no smell and is therefore very difficult to detect with the human senses. Under normal conditions, in a room where fuel burning appliances are well maintained and correctly ventilated, the amount of carbon monoxide released into the room by appliances is not dangerous. These fuels include: wood, coal, charcoal, oil, natural gas, gasoline, kerosene, and propane.

Such gases can build up in the blood interfering with they body's ability to supply oxygen to itself.

### **Smoke Alarm**

Due to having open flame while cooking, propane in or on coach, it is required to have a smoke alarm placed on ceiling between bedroom and kitchen.

Energy to operate this alarm is supplied by 9 volt battery inside of alarm. Battery must be tested each week to make sure it operates correctly while using your camper.

**Operation:** The smoke alarm is operation once the battery is correctly connected. The LED will flash every minute to show the battery is supplying power to the alarm. When production of combustion are sensed, the unit sounds a loud alarm which continues until the air is cleared.

**Testing:** Test the alarm by pushing the test button on the smoke alarm cover for at least three seconds, until the alarm sounds. The alarm sounds if all electronic circuitry, horn and battery are working. If no alarm sounds, the unit has a defective battery or other failure and should be replaced immediately.

- Test smoke alarms before going on vacation. Also test when no one has been in the RV for several days.
- Stand at arm's length from the smoke alarm when testing. The alarm horn is loud to alert you to an emergency. The alarm horn may be harmful to your hearing.
- The test button accurately tests all functions. Never use an open flame from a match or lighter to test this smoke alarm. You may ignite and set fire to the smoke alarm and your home.
- **MOBILE HOME AND RV LOCATIONS— TEST SMOKE ALARM OPERATON AFTER VEHICLE HAS BEEN IN STORAGE, BEFORE EACH TRIP, AND AT LEAST ONCE PER WEEK DURING US**



## **WARNING**

Test smoke alarm operation after vehicle has been in storage, before each trip, and at least once per week during use. Failure to comply may result in serious injury.

### **FIRE EXTINGUISHER**

A fire extinguisher is installed in each vehicle and is located near the entrance door. Be familiar with its location and operating instructions as printed on the extinguisher. Inspect the fire extinguisher spring and fall.

Extinguisher is rated at 5 or 10 B.C. as required for recreational vehicles



## **CAUTION**

After lubrication, be sure no lubricant is remaining on step, causing a person to slip.

### **STEPS ( 2 OR 3)**

Before entering your recreational vehicle place your hand in the center of the step assembly. Pull the step outwards. The step assembly will raise slightly and then out, away from the coach. The lower step will unfold 180° to useable position. The arm on the step will meet a positive stop. Step care, maintenance and lubrication will be found in the maintenance manual.

Step care, maintenance and lubrication information will be found in Chapter Seven - Mechanical Maintenance

### **Windows**

All windows are of slider opening design, solid picture window or opening vent panels. Sliders may open horizontal or vertical as called for per floor plan. Egress (Escape) windows have an unlocking handle or two small hinged clips on each side. After unlatching, the panel will swing out on a top hinge. On some Egress (Escape) windows screens are attached to swing out panel of window.

### **Doors**

Locks on entrance doors have two lock mechanisms, a deadbolt in the frame section of lock and a standard lock in the handle. Both locks use the same key.

Screen doors may have two types of latches. First, a "roller" latch and secondly, a "hook" latch which needs to be tripped to open.

Locks on trunk doors need a small quantity of silicone lubricant sprayed internally two times per year to keep functioning correctly

### TV Antennas (Standard Roof Mount)

To raise the antenna turn crank clockwise in UP direction approximately 13 turns or until some resistance to turning is noted (figure 1).

On amplified models, 12-volt DC power is required for full performance. Turn the power supply ON with the push button switch (figure 2). Power moves to the head of antenna, activating the inbuilt module, returning amplified signal to both coax leads in the coach.

After the antenna is in full UP position, pull down on the round knob with both hands until it disengages from the ceiling plate. Rotate for best picture (figure 3).

To lower the antenna to traveling position, rotate the antenna until pointer on directional handle aligns with pointer on the ceiling plate. Turn the elevating crank counterclockwise in DOWN direction about 13 turns or until resistance is noted. The antenna is now locked in travel position (figure 4).

*To test system:*

1. Make sure the television is working properly.
2. Switch the power supply ON and OFF to see if there is a difference in the picture quality while watching TV. If no difference, test for 12 volt power at the cable on the roof top, as 12 volt power must be there to activate the power booster in the antenna head.

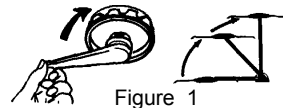

Figure 1



Figure 2

**WARNING**  
DO NOT connect high current devices such as hair dryers to this receptacle. Maximum current rating of this receptacle is 7.5 amps at 12 VDC.



Figure 3

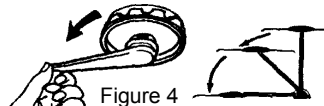

Figure 4



## CAUTION

When lowering the antenna, never, lower it into any position except the TRAVEL POSITION. Failure to lower antenna into the TRAVEL POSITION before traveling will very possibly cause damage, not covered by warranty.



## CAUTION

The power supply should be turned OFF when connecting/disconnecting cables to power supply and antenna,

### SLIDE OUTS

Slide outs come in many sizes and different systems. In this model you have what is called "Above floor slide-out"-all components are located inside and above floor, under sofa or under dinette. A single ram attached slide and is access-able inside on floor and lag bolts from ram mount into outer wall. Slide must be moved out 6 to 8 inches access the outer bolts on the outside.

### OPERATION

All power slides operate on 12 volt DC power provided by fully charged auxiliary battery or converter. Through a 12 volt distribution load center, 30 amp breaker, supplies power and safety for operation. For best performance, have 120 volt power attached. Tow vehicle power can be used if required. The 30 amp breaker will automatically reset if needed.

Power is supplied to 12 volt motor when switch is pressed.

Switch is normally located under an overhead cabinet, generally in kitchen area. Switch is spring loaded so you will need to hold it while moving slide.

**OPEN:** Hold operation switch until room seals tightly on the exterior of the unit. DO NOT distort or bend the exterior flanges or interior fascia by holding switch in the "ON" position

**CLOSE;** To retract, Hold button until the room is fully inside with gaskets sealing to the outer wall. It takes about 20 seconds to move slide in or out.

No blocking is required or suggested to be used under slide-outs during extended use.



#### Manual Over-ride

Should 12 volt power fail and there is no 120 AC power be available ,follow the listed directions. Access to the ram is under the floor of slide, sofa or dinette, is the from the inside. A 5/8 inch socket is required plus ratchet and extension. Place socket on provided nut supplied by the manufacturer .of system . Turn in the direction needed to move slide-out.

There may be minor resistance but should move fairly easily.



**DANGER**

- \*Always make sure that the trailer is level before operating slide-out room.
- \*Always make sure that there are no obstructions blocking the path of the room when it is moving.
- \*Always make sure that the path is clear of people and objects before operating.
- \*Always keep away from the slide rails under the coach when room is in motion.

**FAILURE TO FOLLOW THESE INSTRUCTIONS COULD RESULT IN SERIOUS INJURY OR DEATH.**

#### NOTE;

- 1, Before operating the slide-out room ,level trailer front to rear and side to side.
2. Extend all stabilizer jacks to make solid contact with ground and/or solid blocks. Placing stabilizer jacks onto a hard surface allows the coach to remain square and assures a good weather tight seal between the room and trailer sidewall

#### TOY HAULER GROUP

Toy haulers, Classic and Escape offer numerous opportunities to transport your “toys” within permitted weight limits. The front end of coach is a fully equipped recreational vehicle with rear portion available for cargo items.

In a Toy Hauler you may place 40% of allowed cargo weight in the rear space. The remaining 60% is to be distributed in the front. For every two pounds in front of the axle, one pound should be behind the axle.

.Excess weight behind the axle lightens hitch weight ,may cause sway when passing vehicles and gusty winds are present.

Since these coaches are designed and built to carry such cargo in the rear portion of the unit, special care must be exercised in loading to prevent potential handling concerns.

Any cargo in rear area **MUST BE** secured during movement. For this reason there are “D” rings provided in in each coach.



**CAUTION**

The tie downs provided are for general purpose use (rating 1500 pounds each)

The transport of certain types of cargo (motorcycles, bikes, etc.), may require additional accessories for secure transport. Please refer to owners manuals or contact the manufactures of these specific items for more information.

Any two (2) wheel items such as bicycles and motorcycles will require additional support for front wheel such as a “wheel chock”. Any such stabilizer item **MUST** be anchored with bolts and nuts through floor and/or solid material. Floor material only will not hold the wheel chock.

When internal combustion engines are stored and transported inside of the cargo area, your living quarters has restricted usage. Fumes from gasoline in engines are hazards to the respiratory system of human beings and pets. After removing vehicles containing gasoline, ventilation is required for 3 hours before occupying the recreational vehicle.

Sleeping or occupying this area, care must be taken. There are two (2) vents located ,one on each side they **MUST** be open. when gasoline filled equipment is present.

Sleeping opportunities in cargo area :

\* Fold up sofas are available, secured to sidewall and will fold out as a bed when cargo is removed.

## FUEL IN CARGO AREA

**! DANGER**

**ANY MOTORIZED VEHICLE OR ANY MOTORIZED EQUIPMENT POWERED WITH FLAMMABLE LIQUID CAN CAUSE FIRE, EXPLOSION, OR ASPHYXIATION IF STORED OR TRANSPORTED WITHIN THE RECREATIONAL VEHICLE. TO REDUCE THE RISK OF FIRE, EXPLOSION, OR ASPHYXIATION:**

- 1. Do not ride in the vehicle storage area while vehicles are present.**
- 2. Do not sleep in the vehicle storage area while vehicles are present.**
- 3. Close doors and windows in walls of separation (if installed) while any vehicle is present.**
- 4. Run fuel out of engines of stored vehicles after shutting off fuel at the tank.**
- 5. Do not store, transport, or dispense fuel inside this vehicle.**
- 6. Open the windows, openings, or air ventilation systems provided for venting the transportation area when vehicles are present.**
- 7. Do not operate propane appliances, pilot lights, or electrical equipment when motorized vehicles are present.**

**!!! DANGER !!!**

**FAILURE TO COMPLY COULD RESULT IN AN INCREASED RISK OF FIRE, EXPLOSION, ASPHYXIATION, DEATH, OR SERIOUS INJURY.**

## REAR CARGO DOOR

Rear door on Classic and Escape coaches have “Spring Loaded”, preset and designed springs attached along with hinge assembly. As you lift door up or down, these springs support most of the weight. A double latch on each side ensures tightness when closed. Handle will latch into door lock when closed. Lock may be secured with keys.

## CHAPTER 4 SYSTEMS

### WATER AND DRAINAGE PLUMBING



Your KZ recreational vehicle has a complete water system, to carry fresh water, as well as holding tanks for used water. Each group has its own explanation along with its own operation.

#### Tanks

Water containers are installed inside of the coach under the bed, dinette or sofa.

#### Filling Fresh Water System

Listed below are two methods of placing water into your coach fresh water system:

1. City Water Fill (Figure 1): Water may be received into the system through a direct hook-up referred to as a "city water fill." After attaching a hose to hook-up and supply line, open the faucet from the supply line. Enter the coach and open any faucet to relieve air from the lines. The water heater will fill first before the supply lines. You will experience some air pockets. Allow them to escape before closing faucets.  

2. Gravity Water Fill (figure 2): To place water into the fresh water tank, remove cap from the fill. Insert the hose into the 1-1/4 inch flex tube 4 to 6 inch. Open the water supply faucet. DO NOT overfill the tank as it could burst. It is not designed to hold pressure.  

3. During the tank fill process, check the Tank Monitor Panel (if applicable).

	<b>CAUTION</b>
<b>DO NOT leave tank unattended while filling.</b>	
	<b>DANGER</b>
<b>POTABLE WATER ONLY. SANITIZE, FLUSH AND DRAIN BEFORE USING. SEE INSTRUCTION MANUAL. FAILURE TO COMPLY COULD RESULT IN DEATH OR SERIOUS INJURY.</b>	



## CAUTION

Excessive pressure from water supply systems may be encountered in some parks, especially in mountain regions. Water pressure regulators are available to protect your system against such high pressure. A regulator at 45 pound rating is recommended to prevent damage to the plumbing system or components.

### USING WATER SYSTEM

#### 12 volt demand pump

When water is desired and you are not hooked up to city water, your tank will be your supply. On your monitor panel is a switch to turn on the 12-volt demand pump. Energy for the pump is supplied by the auxiliary battery or converter. The pump will self-prime when started, supply water, and continue to run until approximately 40 pounds of pressure is achieved. When pressure drops to 20 pounds, pump will restart. Some cycling in pump may occur. A check valve is built within the pump to prevent water from flowing into the supply tank.

When pump is not in use, turn 12-volt power off at the switch, located on wall or on monitor panel if so equipped.

The pump has a small filter attached on the "in port" side to prevent any foreign material from entering into pump. You need to annually or oftener unscrew cap and clean out screen or replace it.

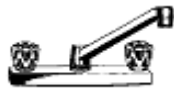

#### Faucets

The basic operation of a faucet is the same as in your home. Open the knobs or raise the single lever. Close faucets when sufficient water volume is achieved. It is normal to experience occasional air pockets in the system.

### Bath and Shower

Your bathtub and shower are built with ABS, Fiberglass & Waterproof Vinyl material, similar to those in your home. Shower curtains are provided with the coach and must be used to prevent water from spilling onto the floor, possibly causing damage.

The shower head used in the bathroom has a non-positive shutoff valve and will drip slightly in shut-off position. A vacuum breaker is also built into the faucet to permit water in hose to drain out as a code requirement.

Before beginning your shower be sure the water heater is lit. Adjust the faucet for temperature before entering the tub or shower. When shower is completed be sure to turn water off at the faucet.

Remember capacities of your water heater and gray water holding tank. Long showers in a recreational vehicle are NOT suggested due to the amount of water that is available. To conserve water, wet down, and turn water off at shower head while you soap up, then rinse.

T= Tank to be filled with fresh water for usage during your camping trip

P= Pump, 12 volt DC= to supply water when city water is not available.

S= Siphon hose-used to winterize or sanitize lines in system only.

V-2= Valve is to be open to draw water from supply tank. Closed when using siphon hose.

V-1= Valve is to open only when using siphon hose to winterize or sanitize line system. Closed when drawing water from tank.

C= City water entry.

G= Gravity water fill.

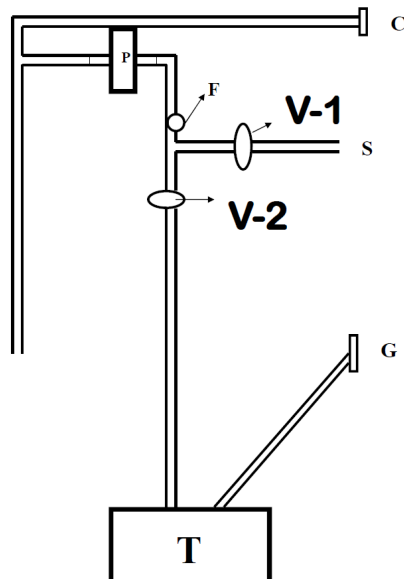

Used water will flow into gray holding tank.

### **Sanitizing and Filling the Potable Water System**

For your safety, you should sanitize your potable water system when your recreational vehicle is new or when it has been sitting unused for a period of time and it may have become contaminated.

Prepare a chlorine solution using 1/4 cup of bleach (5% sodium hypochlorite solution) to one gallon of water. Prepare one gallon of this solution for each 15 gallon capacity of the tank. As designed and constructed, this method will sanitize the plumbing system.

### **For Gravity Fill Storage Tanks:**

1. Close all the drains: tank, low-point drains, and have by-pass closed to water heater.
2. Open lid on gravity fill and pour above contents into tank. A funnel may assist your efforts or be required.
3. You may wish to add additional water for circulation
4. Open all faucets to allow air to escape.
5. Turn on water pump to deliver water solution through coach water lines.
6. Close faucets when air ceases to bubble out.
7. Allow solution to remain in tank and system for 3 hours.
8. Drain solution and flush as desired with fresh water.

### **Drainage (Fresh Water)**

All permanent fresh water tanks can be drained. Two types of drains are used, (1) a push/pull (2) a turn valve with open/close position. Valve is normally close to tank .

To drain the supply lines and the entire system, you need to follow the steps listed below. Locate the valve placed at the floor level or close to the floor, found under the dinette, storage cabinet, and sofa. These valves will be at the "lowest" point of the water lines.

To drain system:

1. Open all faucets including optional exterior shower.
2. Open the fresh water tank drain.
3. Open the water heater drain.
4. Open all (two to four) low-point drains.
5. Open the toilet valve, hold or block if need be.
6. To empty the pump, start and allow to run up to 20 seconds.



**Aqua-Magic V**  
*Hand or pedal flush*

## Sanitation System

### Toilets

Prior to using your toilet, be sure to add a proper amount of deodorant chemical into the toilet with water. Flush contents into tank plus two or three gallons of water.

After each flush, about two inches of water will be in bowl, which is fine for travel. For best operating function, keep four to six inches of water in the bowl. This assists flushing procedure. Always flush for ten seconds or more to ensure all solids and wastes move into tank and are not held in drainage pipes.

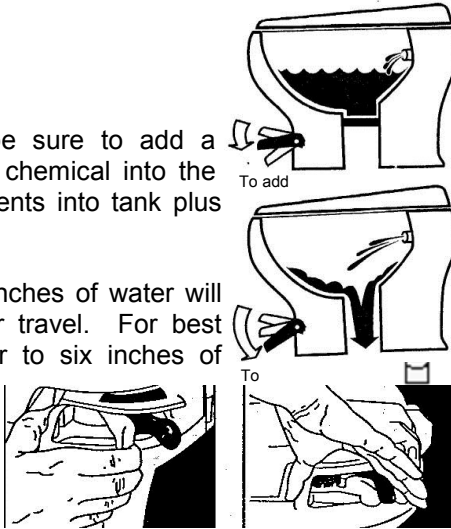

**OPERATION:** Note the photos on page 34 showing movement of pedal down toward the nine o'clock position, you will add water to bowl. Push downward further to eight o'clock position to flush contents into waste tank. Release pedal slowly to close flush operation.

For hand lever operation, pull both levers forward to flush. To add water only pull white lever forward. When releasing lever (s), do so slowly. For foot pedal, half way down, water only, flush, fully down.

Unlike the toilet in your house which uses four to seven gallons of water per flush, a recreational vehicle uses two to three quarts to save water and space. When insufficient water is used during flushing, waste materials may not evacuate properly from drain lines to tank, causing "clogging" in pipe.

When hooked up to a sewer drain at a camp ground, ALWAYS keep the termination valve CLOSED until the tank is at least 3/4 full. This will provide sufficient water to assist in complete draining of tank.

Manufacturer of toilet, Thetford Corp., offers a complete line deodorants, chemicals, and other convenience products for your use. Your dealer can assist you with these needs and may already have them in stock.



### ***Using Toilet and Tank System***

When camping you should always have 4 to 6 inches of water in the toilet bowl. The toilet system performs better when you run water 10 to 20 seconds after flushing to ensure wastes will proceed to the bottom of the tank. If there is not sufficient water used during flushing, waste materials may not evacuate properly from drain line to tank. Tank and pipes could eventually become clogged.

### ***Vents***

A very important part of your sanitation system is the vent system in your coach. These vents release air from holding tanks allowing water to enter. Vent pipes are attached to the holding tank, fed through the walls and cabinets to the roof. On some models a portion of vent pipe may be part of the drainage system referred to as a "wet vent". As air flows upward, water will be draining downward.

### ***Holding Tanks***

The final parts of your sanitation system are the holding tanks for waste materials and water. These are located below the floor of your coach.

*Gray Tank.* Waste water from the bath tub, shower and sinks will drain into this container. No special preparation is required,

	<h1>CAUTION</h1>
<p><b>NEVER</b> leave the gate valve of your coach's sewage tank open when hooked up to a park's sewer system. Open only when you need to drain system.</p>	

however, you may wish to add baking soda or a Thetford chemical to reduce odors from food particles in the system.

*Waste Tank.* The toilet drains into the waste or "black" holding tank. For correct preparation follow the listed steps:

1. Release two quarts of water into the toilet bowl.
2. Place the recommended quantity of chemicals for waste holding tank as per instructions on the bottle into the toilet bowl.
3. Flush liquids into the tank and allow up to two gallons of water to flow into the tank.

Each time you drain the tank, you should follow the above instructions before using.

All drain pipes from sink and shower will have a "P-trap" installed into each line. Water in these traps prevent odors from escaping into the coach. During travel, water from the P-traps may spill and permit odors into the coach. These odors come from fats and food particles decomposing in the tank. By adding water and using a RV approved deodorizing agent, contents will dissolve faster, keeping the drain lines and tanks clean and free flowing. These chemicals are available at a RV supply store.

	<h1>CAUTION</h1>
<p><b>It is important to use adequate water to flush and have several gallons of water with chemicals in the tank. This helps the flow of wastes and reduces solid waste build-up.</b></p>	

### ***Draining the Tanks***

A final part of your sanitation system is the drainage of holding tanks. Realizing dump stations will vary, place the coach as level as possible to make drainage easier. Some tanks drain from the center requiring level or slightly up in front. Others will drain from end permitting a slight tilting to the side which drains are on.

Make sure the Dump Valves are closed before removing the cap and attach the adapter onto the valve housing. Turn the adapter 10° to lock onto the pegs. Attach a flexible sewer hose to the adapter and secure with a clamp. Place the other end into the approved sewer system.

You may now open the valve to drain the sewage tank first. Open the valve on the gray water tank last to utilize water to wash and rinse the hose and drain lines.

Most states and parks have strict laws and regulations to prohibit dumping of wastes of any kind into anything other than proper disposal facilities or sewer systems. Almost all privately owned parks have either a central pump facility or offer a campsite hookup for sewage. You can find lists of many dump facilities throughout the United States in *Woodall's*, *Rand McNally Camp Guide*, *Good Sam Camp Guide*, *KOA Campgrounds Camp Guide*, or various other publications. Some fuel stations also have dump stations.

### ***Maintenance for Holding Tanks***

The following maintenance is recommended by our holding tank suppliers to keep your tanks clean and keep the probes feeding information to monitor panel free of debris and build-up.

*Gray (Waste-Water) Tank.* Fill tank with 5-8 gallons of warm water. Add a degreaser such as a citrus cleaner or Dawn dish soap. Leave solution in tank while you are traveling. Rinse and drain tank.

*Black (Sewer) Tank.* Fill tank with 3-5 gallons of water. Add one bottle of drain cleaner, such as Drano or Liquid Plumber. Leave the solution in tank while traveling. Rinse and drain tank.

### **Winterizing Your Recreational Vehicle**

Preparing your trailer for cold weather is very important for most states and Canada. Failure to prepare your coach for cold weather will cause the water systems to freeze resulting in breakage. Damages related to freezing are not covered under the terms of your limited warranty.

Two methods of winterizing your coach after draining and flushing your drainage system are listed on the next page.

#### ***Method 1:***

1. Open all faucets, low point drains and toilet valve to drain all water. Leave these open during this procedure.
2. Start pump and operate until all water has been removed, takes about 10 to 15 seconds.
3. After water has been drained, use an air hose from compressor and an adapter attached to city water fill. In about 3 to 5 minutes all water will be blown out of system.
4. Pour one (1) cup (8oz) of non-toxic RV anti-freeze into each P-Trap, two in sinks and one in bathtub.

#### **Method 2 Using RV antifreeze in lines.**

The water heater "By pass kit" will prevent antifreeze from going into water heater, located behind water heater with 2 valves.

1. Turn off the pump.
2. Drain the water heater and the entire water system at low-point drain valves.
3. Place siphon hose into container with antifreeze.
4. Valve V-1 must be open and V-2 must be closed. See diagram on page 32.
5. Open all faucets for air to escape..
6. Turn on water pump to supply water lines with antifreeze. It may take 2 gallons or more, depending on length of lines.

7. You may wish to place a container under faucet to catch extra antifreeze.
8. Closest faucet to pump will fill first. Turn each faucet off as antifreeze comes through.
9. Turn pump off when all faucets emit antifreeze.
10. Take contents in container and pour up to 1 pint of antifreeze into each p-trap for freeze protection.
11. Any left over antifreeze back into container for future use.

#### USING THE WATER SYSTEM DURING FREEZEING WEATHER

Your towable coach was not designed to be used during freezing weather unless special precautions are taken. Water freezes at 32° Fahrenheit in campgrounds or at home.

There is no product that can be added to the water to ensure freeze protection when the system is in use, other than RV anti-freeze. DO NOT drink water which contains anti-freeze.



# DANGER

**DO NOT use Ethylene Glycol (automotive antifreeze) or Methanol (windshield washer antifreeze) in your fresh water system because they are harmful and may be fatal if swallowed!**

The flush system is designed and built to rinse waste to holding tank AFTER waste tank has been drained completely of water and solids.

Attach a fresh water base connection marked “San-a-flush.” Be sure termination valves are open on holding tank (s).

Open valve to release water into tank for rinsing and cleaning of your waste holding tank.  
Rinse for several minutes to remove any foreign matter from tank.

Remember the moisture content may give you a false reading on your monitor panel indicating it is full. Allow time to dry out tank or recharge for next use.

## PROPANE FUEL SYSTEM

The fuel system in your recreational vehicle has numerous components such as, piping, copper tubing, brass connectors, hoses, regulators and appliances. Each of these components will be explained in its appropriate area.

Propane is the only fuel permitted to be used in a recreational vehicle and its appliances. This product is refined from crude oil through natural gasses. An agent has been added for detection should a leak occur or a valve accidentally be left open. It is important for a recreational vehicle owner to recognize and identify the smell of propane vapor.

Butane cannot be used since its boiling point is 30°F. This fuel will not flow in freezing temperatures.

Natural gas and butane CANNOT be used in any KZRV or it's appliances.

Propane fuel is stored in liquid form under high pressure in special containers. Boiling point is (minus) —44 degrees the temperature when vapor ceases to flow. Fuel will change to vapor when released from the container. Appliances are not designed to operate with liquid. Liquid will damage O-rings in valves and also leave sticky, oily residue causing poor or no operation in the regulator.

For every 10 degree increase in temperature, the pressure of propane in container rises 1.5%. Example— fill at 0 degrees in north, go south to 80 degrees , you now have a container filled at 92%, a potential problem with 10% valve spewing out propane vapor.

### Propane Container

The propane cylinder is D.O.T. approved container to hold liquid under high pressure, normally a 20 or 30 pound capacity.

The open/closing valve, referred to as an acme cylinder valve, is to be closed at all times unless hooked up to a propane system or when filling the container.

Acme Cylinder Valve

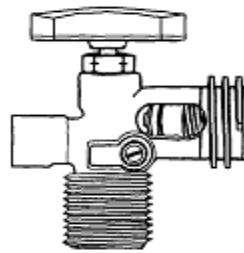

At any point a container is disconnected, BE SURE to install the "dust cap" over the acme valve. This cover is required by the RV Industry Gas Association, the container manufacturer, and is for

your safety.( if so equipped)

Whenever the container is detached from the propane system, DO NOT allow the cylinder to move or roll around during transporting to and from the gas supplier.

A second smaller valve is built into the main valve to prevent fuel from escaping. A hose with an acme fitting or a POL fitting must be completely and tightly installed before gas vapor can be withdrawn.

This valve, also referred to as an OPD valve (overfill protection device) has a float device inside of the cylinder to prevent overfilling of the container.

### **Servicing and Filling Propane Containers**

Filling a propane container must be done carefully and correctly. Only a qualified person, properly trained on inspection, filling and safety procedures, should fill containers.



A new container must be “purged” before placing into service and must NEVER BE OVERFILLED. Purging is an operation performed by your dealer or propane agency to remove any atmospheric air. As an owner you need not be concerned regarding this procedure unless you permit the valve to be in OPEN position when empty.

Two overfill devices are built into the valve to prevent overfilling of the container. First, is the small brass “knob” or “screw” inside of the valve. This “10% valve” must be open when filling, allowing air to escape. When the container reaches 80% of the correct capacity, liquid appears.

Secondly, containers with OPD valves have a float on the inside that automatically shuts off liquid flow when the 80% capacity has been reached.

When refilling propane containers, they are generally removed from propane compartment or tie downs. BE SURE to reinstall correctly, as shown in installation instructions, and test for leaks.

When propane containers are filled to 80% level there is available space for safe expansion of the vaporized liquid. Should your con-

tainer become slightly overfilled, pressure may rise due to hot sun.

 **WARNING**

Never smoke during the filling of propane tanks. Keep the recreational vehicle away from immediate filling area when possible or extinguish all gas pilots.

 **DANGER**

A warning label has been located near the propane container. This label reads as follows:

**DO NOT FILL CONTAINER(S) TO MORE THAN 80 PERCENT OF CAPACITY.**

1. Overfilling the propane container can result in uncontrolled gas flow, which can cause fire or explosion.
2. A properly filled container will contain approximately 80 percent of its volume as propane.

 **DANGER**

Propane cylinders shall not be placed or stored inside the vehicle. Propane cylinders are equipped with safety devices that relieve excessive pressure by discharging gas to the atmosphere.

**FAILURE TO COMPLY COULD RESULT IN DEATH OR SERIOUS INJURY.**

It could cause the overflow valve to “blow-off” and emit a small quantity of propane vapor. This can be detected by a strong odor around tanks. Keep open flames away from this area. It is best to remove the bottle, take it to a safe area, and burn off propane with a special torch to reduce quantity of propane.

When disconnecting propane containers, you must turn the ACME fitting in a clockwise direction because left-hand threads are utilized. When reconnecting, turn connections counterclockwise. Connections must be tight, however DO NOT over-tighten.

## Installing Propane Containers

1. Knob to open and close main valve.
2. Complete valve assembly.
3. "10% valve", (small brass knob or slot screw).
4. Container mounting stand.

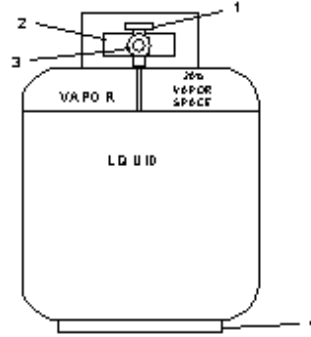

## DANGER

Your vehicle has exterior combustion air inlets. Appliance pilot lights should be turned off during gasoline or propane refueling. (Required by law in some states.)



## CAUTION

**THIS GAS PIPING SYSTEM IS DESIGNED FOR USE WITH PROPANE ONLY. DO NOT CONNECT NATURAL GAS TO THIS SYSTEM.**

Securely cap inlet when not connected for use. After turning on gas, except after normal cylinder replacement, test gas piping and connections to appliances for leakage with soapy water or bubble solution. Do not use soap products that contain ammonia or chlorine.

**ALL PROPANE LINES HAVE BEEN CHECKED WITH AIR PRESSURE. DEALERS ARE REQUIRED TO RECHECK BEFORE DELIVERY TO RETAIL CUSTOMERS.**



Classic and Escape recreational vehicles are equipped with 1 -20 pound propane container for each coach.

Mounting and attaching instructions are listed below:

1. Locate the pre-installed screws (2) in the top of A-frame near tongue jack at front end.
2. Remove both screws and re-stall with propane bottle ring.
3. Attach regulator to bracket, welded on ring (4 screws)
4. Attach hi-pressure hose to top side of regulator.
5. Attach lo-pressure hose to bottom side of regulator.
6. Attach brass swivel nut to bulkhead fitting on the coach.
7. Place filled bottle into ring and tighten wing nut to secure bottle.
8. Attach ACME fitting of hi-pressure hose onto the bottle.
9. Be sure ALL fittings are tight.
10. Open valve of bottle SLOWLY.
11. Test ALL (4) connections for leaks. (Use soapy water in which soap does NOT contain ammonia or chlorine .)

### **Regulator**

Propane regulators must always be installed with the regulator vent facing downward. Regulators that are not in compartments have been equipped with a protective cover. Make sure that the regulator vent faces downward and that the cover is kept in place to prevent vent blockage . Should vent be covered, regulator CAN-NOT function.



The regulator has the only moving components in the propane system. It's sole function is to reduce the high and varied pressure from the propane containers to safe and consistent low operating pressure. The small inlet is the first stage, which reduces the container pressure to 10-13 pounds.

The second stage then reduces the 10-13 pound pressure to an operating pressure of 11 inches W.C. (water column) or 6.35 ounces of outlet pressure to your appliances. The second stage is adjustable and may need to be adjusted for precise operation. We suggest this to be normal maintenance and performed once per year. Do not make this adjustment without a manometer. This instrument is required to read actual pressure.

If pressure is too high, it affects performance and safety. Should

pressure be too low, appliances will not operate correctly. An authorized and competent technician with proper equipment should perform such tests and adjustments, as may be required.

Your propane regulators are used on Classic and Escape products. is the standard two stage regulator . This standard regulator is used on smaller coaches.

After filling the cylinder, connect the pigtail hose and slowly open the bottle valve. Do not forget to check for leakage each time you refill cylinder or disconnect any part on the propane system.

### High Pressure Hoses with ACME Connectors

Propane leaves the container through a hose with an ACME connector attached to the bottle, also having a “flow-limiting device”. Should the container valve be opened too quickly this device may close, stopping the flow of propane. This device is designed to equalize propane pressures in about 5 seconds, generally being unnoticed. All pilot light valves must be turned off for equalization of pressure to occur.



3/8" MPT x 1/2" Female  
Flare Swivel

### Main Supply Hose – Low Pressure

The main supply hose will be attached to the regulator and manifold fitting attached to front cross member of frame .

The swivel brass nut on the main hose will be your final attachment.

There are several things to remember each time the container is removed:

1. Be sure ALL fittings are tight. Always use two open end or 6 point wrenches for brass connections.
2. Be sure ALL connections are tested for leakage.
3. Open the main valve slowly to avoid a fast rush of gas to flow-limiting device causing gas “freeze” .
4. Listen carefully – a “hissing” sound longer than one second may

indicate a gas leak. Close valve and search for leak.

Should you experience a gas “freeze-up”, close the main valve and wait 15 minutes before trying again. Keep the container valve(s) closed when traveling. Some states prohibit traveling with the propane container valves open, especially in underground tunnels on expressways.

#### **Operation**

After the camper is completely set up and you are prepared for camping enjoyment, follow these steps for propane operation.

1. Be sure ALL burner valves, controls, and pilot light valves are closed.
2. Open main valve on propane container slowly to avoid a fast rush through excess flow valve causing “gas freeze”.
3. Listen carefully as gas begins to flow. If a “hissing” sound is heard for more than one or two seconds, close valve and search for a potential leak. Solve leak before proceeding .
4. Light appliances as needed and directed in Chapter Five-Appliances.

The entire propane distribution system and appliances have gone through complete factory and dealer tests for any leakage. When traveling with your RV normal vibrations and road movement may cause connections to loosen and develop leaks.

For normal maintenance we advise all owners to test for leakage at least once per year or more often. You may request your dealer to perform a maintenance check each spring.

Should you encounter an odor, possibly propane, turn off any and all open flames and begin a systematic search for leaks on the complete gas system. NEVER USE A MATCH. Use a soapy water solution which contains NO AMMONIA, or CHLORINE content to check for leaks. If a leak is identified, bubbles will appear. ALWAYS use two open end or 6 point wrenches when tightening brass connections to prevent twisting of copper.

For your own protection, the preceding warning label has been placed near the cooking area to remind you of the need of oxygen for combustion and breathing. Due to smaller area in your recreational vehicle, there is less oxygen than in your home. Proper ventilation is required when cooking.

It is especially important that cooking appliances **not be used for comfort heating**, as the danger of asphyxiation and unsafe levels of carbon monoxide are greater when the appliance is used for

**DANGER**



Portable fuel-burning equipment, including wood and charcoal grills and stoves, shall not be used inside the recreational vehicle. The use of this equipment inside the recreational vehicle may cause fire or asphyxiation.



**DANGER**

**If You Smell Gas:**

1. Extinguish any open flames, pilot lights, and all smoking materials.
  2. Do not touch electrical switches.
  3. Shut off the gas supply at the tank valve (s) or gas supply connection.
  4. Open doors and other ventilating openings.
  5. Leave area until the odor clears.
  6. Have the gas system checked and leakage source corrected before using again.
- FAILURE TO COMPLY COULD RESULT IN EXPLOSION RESULTING IN DEATH OR SERIOUS INJURY.

long periods of time

**Propane Consumption**

All your propane appliances are operated intermittently. Your furnace is naturally the appliance using the most fuel, especially if freezing conditions are present outside. On a very cold and windy day it is conceivable that your coach could consume most of a 30 pound propane bottle.

Propane consumption depends mostly upon individual use of appliances and the length of time operated. Each gallon of propane produces about 91,500 BTUs of heat energy. Following is a list of typical appliance consumption when turned on fully for one hour of operation:



## DANGER

**IT IS NOT SAFE TO USE COOKING APPLIANCES FOR COMFORT HEATING.**

Cooking appliances need fresh air for safe operation.

Before operation:

1. Open overhead vent or turn on exhaust fan
2. Open window

**FAILURE TO COMPLY COULD RESULT IN DEATH OR SERIOUS INJURY.**

Unlike homes, the amount of oxygen supply is limited due to the size of the recreational vehicle, and proper ventilation when using the cooking appliance (s) avoid dangers of asphyxiation. It is especially important that cooking appliances NOT be used for comfort heating, as the danger of asphyxiation is great when the appliance( s) are used for long periods of time.

**FAILURE TO COMPLY COULD RESULT IN DEATH OR SERIOUS INJURY.**

APPLIANCES	LP GAS CONSUMPTION
Water Heater	8,800-12,000 BTU
Furnace	16,000 BTU
Stove/Oven	6,500-13,000 BTU
Refer (3,4 Cubic)	875-1,420 BTU
Note: The above chart represents many different models.	

## ELECTRICAL SYSTEM

### General Information

The electrical system in your recreational vehicle is designed using both 120 volt AC (alternating current) and 12 volt DC (direct current) capabilities. All installations and designs are built to comply with safety requirements of ANSI standard 1192, National Electric Code and Canadian Standards Association.

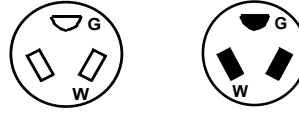

30-A, 125-V, 2-pole, 3-wire,  
grounding type

### Changes and Modifications

Any changes, alterations, additions, and/or modifications need to be performed by qualified electrical technicians, using only approved components which meet safety and code requirements. This includes owners, dealers, etc. who desire to make changes. The manufacturer is not responsible for any changes, or alterations, made to the 120 AC system of the coach.

### Power Cord 30 AMP

A 30 amp rated power cord is pre-wired into your 120-volt AC breaker box. Open the hatch door on the exterior of the coach. Pull cord out and attach it to 120-volt power source.

Energy will enter through the main breaker and is distributed through circuit breakers to the wall receptacles and appliances. This power cord will be approximately 26 to 36 feet in length. Each cord has the correct gauge of wire to carry the correct voltage to coach.

In some hook-ups the power cord may not be long enough and extension cords are required. ALWAYS use a cord with the gauge of wire equal to or greater than the power cord. Should you use a cord with a smaller wire, overheating, loss of amperage, and possible melting could occur.

DO NOT leave any unused portion of an extension cord in a "coil" as it may overheat, short-circuit wires and potentially destroy your extension cord.

### ***Circuit Breakers in load center with convertor***

On a 30 amp system, a maximum of six distribution circuits are permitted. All breakers are sized according to power needs on each line.

The following generic drawing shows the circuit breaker alignment with number one being the main breaker on all floor plans.

Depending on the size, floor plan and options of your coach, circuit three through six will vary and possibly not all circuits will be used. Number two is generally the 20 amp air conditioner circuit. Number 1 is 30 amp for main breaker in coming.

An owner must realize and understand that a coach has a total of 30 amp service available to be used. Conserving and choosing which appliance has priority in consumption needs to be part of the planning.

Don't forget loose items such as toasters, electric skillets, and coffee pots also consume power.

**! WARNING**

Never use a "cheater" plug or extension cord which breaks the continuity of the ground circuit to the grounding pin.

**! WARNING**

Do not replace breakers or fuses with any that are rated at a higher amperage. Over fusing may cause a fire by overheating the wire.

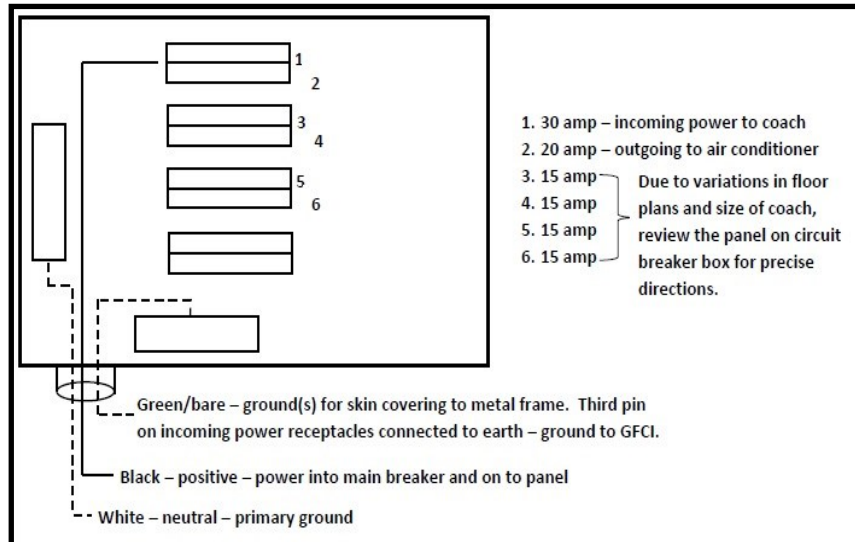



## DANGER

**NEVER, under any circumstances, remove a grounding pin in any cord or plug. It may mean the difference between LIFE OR DEATH.**

### ***GFCI Protection***

Each coach has a GFCI, Ground Fault Circuit Interrupter, protection receptacle installed into the circuitry. This GFCI device is designed to protect people from hazards of line to ground electric shock. The purpose is to reduce possible injury caused by electrical shock, resulting from faulty insulation, improper polarity and related to moisture and/or earth ground.

The third “round” pin on the receptacle is very important for this safety device to function correctly. NEVER cut off this pin. When using an appliance in the receptacle without this provision, use an adapter with a pigtail to be attached to the receptacle box to complete the circuit.

This GFCI receptacle will not protect against short-circuits or overloads. The circuit breaker or fuse in the electrical panel which supplies power to the circuit provides this protection.

Polarity is extremely important. You should be certain that the polarity of the external power is not reversed, in order to avoid harm to appliances and personal electrical shock. Polarity testers may be purchased in most electrical and hardware stores with the GFCI tester built in.

During use of the recreational vehicle it is suggested to test this receptacle once per month. To test press the “TEST” button in. The “RESET” button should pop out. Power should now be turned off at this receptacle and any receptacles down line. To restore power push, then release the “RESET” button.

### **12-Volt DC System**

Most interior lights and appliances receive 12-volt DC power through converter output and/or the auxiliary battery. Exterior lights and brakes also use 12-volt DC power from the tow vehicle battery and/or auxiliary battery through the seven way connector and wire attached to the tow vehicle. Following are explanations of various items.



### **Converter**

The heart of your 12 volt DC system is enclosed inside of load center, including 12V fuse panel, 120V breaker panel and converter.

Fuse panel has 6 or more 12 volt DC fuse positions, depending on output size of your converter. These fuses are mostly 15 amp in size. 30 amp 12 volt breaker is for slide out if so installed. A 40 amp fuse is also in load center for protection should a battery be installed backwards as protection for convertor.

All converters have solid state electronic components internally to produce "clean" 12V DC power.

This load center will have a brown plastic front (World Friendship).

Some models have fuses and breakers in a distribution box, with converter installed in a different location (not mounted into distribution box).

The function of a converter is to take 120 volt AC power and transform this energy into 12 volt DC. ,clean power .Convertor then performs as follows through fuse panel:

- 1.Supplies power to the lights in coach.
- 2.Supplies power to all appliances as required for operation.
- 3.Provides charging voltage for optional battery if so installed.

No manual switches are needed required for this operation

Each converter has a "built-in" fan which operates through a load sensor control or temperature sensor. As more current is drawn, fan will speed up, run faster, or slow down, based on amp draw and/or temperature. Should the fan not run at all, the converter may overheat and will cut-out and/or stop

### **Auxiliary Battery**

All coaches are pre-built to accept an Auxiliary Battery, not provided by manufacture of your coach.

Recommended batteries are of deep-cycle type as you need longer, slow consuming power rather than cold-cranking power. A battery is always required for a break-away switch to function.

A battery requires routine maintenance for long life. First, terminals need to be kept clean to avoid corrosion. Second, a battery used

daily will consume water as long as the converter is in operation. Be sure to check the battery no less than every 30 days and keep the battery filled with distilled (rain) water. Because of constant product change your battery experts is your local supplier.

A converter will not overcharge a battery unless a battery has a dead cell, or the converter has a malfunction. Some type of converters have full battery charge shut-off. Other types reduce the rate of charge as battery conditions reach 12.7 volts DC or 1.265 specific gravity at 80°F. By electronic standards, a battery is discharged at 10.5 volts. Dropping voltage lower than 10.5 volts will begin damaging plates in the battery. Keep your battery charged at all times.

The interior lights will operate from the converter and/or auxiliary battery. Some lights will have wall switches and other lights have switches in the lights themselves.

#### ***Circuit Breakers and Fuses—12 Volt DC***

These two items have been installed in your coach to protect circuitry and components:

Fuses are placed in your electrical system to protect wiring and components when overloads appear or short circuits occur. Radios, stereos and possibly other components may have “in-line” fuses attached to their own wire harness.

*Circuit breakers* are placed at several locations. First, a manual or automatic reset breaker is placed within 18 inches of the auxiliary battery. Automatic reset breakers will “reset” by themselves in 15 to 30 seconds when tripped.

All wiring used in your coach meets correct amp rating correlated with fuses and breakers in respective panels as required by code.

The RV battery is placed in parallel circuitry with the battery on your tow vehicle. Care needs to be exercised not to drain both batteries together. There are two methods of preventing this condition:

First , disconnect the tow vehicle when parked and/or using your coach.

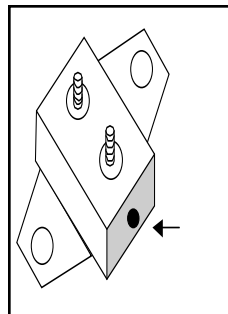



# DANGER

**DO NOT** replace circuit breakers or fuses with a higher current rating than those supplied with your coach. Over-fusing can cause a fire hazard by overheating the electrical wiring.

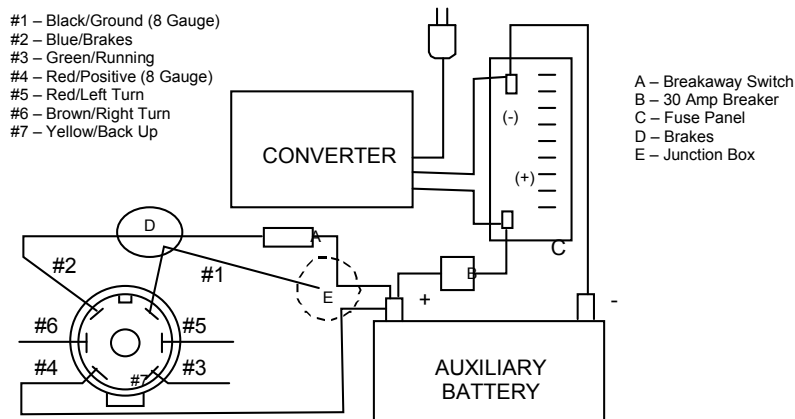

purposes. First, it sends current from the alternator to both batteries simultaneously. Secondly, the isolator prevents power draw from tow vehicle battery preserving power to start engine.

Contact your dealer should you desire an isolator for your protection. Two types are available, mechanical type, or solid state which is the best and most expensive

## EXTERIOR LIGHTS AND CONNECTOR, 12 VOLT DC

### ***Exterior Lights and Connector, 12 Volt***

Power for exterior lights, such as tail lights, turn, clearance and brake lights, is supplied by the tow vehicle.

Note the diagram (above) showing the color code and numbers from the seven way connector and how power is fed to the exterior lights. The positive red wire is attached to the battery to transfer power to the coach.

The connector between the recreational vehicle and the tow vehicle may build up corrosion due to moisture. You may need to clean these terminals occasionally to insure good electrical contact.

***Porch Lights***

Porch lights are placed on sidewalls, normally on door side. Switches for these lights, depending on models, will be on the right side, possibly on over head cabinet. Occasionally, the switch will be on the light itself.

***Brake Wiring***

Both 10 and 12 inch electric brakes operate on 12-volt power supplied from the tow vehicle, transferred through the blue-positive and white-negative in the seven way harness. There are no fuses or breakers installed in this brake wiring. More information on the brake system is found in Chapter Three - Using Your RV.



**CAUTION**

Any electrical installation that does not meet the criteria of the manufacturer's specification will VOID THE WARRANTY on the electrical system.

## CHAPTER 5 APPLIANCES

KZRV places quality-built equipment, as guided by current codes and standards, in all recreational vehicles. Some appliances are built and equipped to operate on propane gas ONLY. DO NOT attempt to operate on natural, or butane gas.

Each appliance has its own specific manual, written and published by its manufacturer. These manuals supply additional information about the appliances in your recreational vehicle.

### FURNACE

The furnace in your recreational vehicle requires 12-volt DC electrical current and propane fuel energy for complete operation. The furnace receives 12-volt DC power from a fully charged battery and/or the convertor in the coach. This power must be present before propane can enter through the control to the burner tube.

The combustion chamber is completely sealed to prevent any carbon monoxide from entering into the coach. Oxygen is drawn into the chamber through the upper vent and exhaust fumes expelled through the lower vent.

Your basic operation is performed through a thermostat to operate furnace.

The thermostat as shown here is installed into coaches which DO NOT have central air conditioning. There is an "ON/OFF" switch on the left upper corner.



#### Operating Instructions.

1. Before operating your furnace, read and be familiar with all safety and warning information concerning furnace supplied by the manufacturer of the furnace.
2. Allow 5 minutes of time with windows and door to be open , allowing full ventilation should any propane odors remain inside.
3. Be sure your propane container valve is turned open and 12 volt DC power is available. A switch is on side of furnace, must be turned "ON" . If blower runs, switch is in "ON" position.

4. Slide thermostat lever from "OFF" position to 60 degrees.
5. Blower will come in 15 seconds and run about 30 seconds to purge heat chamber.
6. Module board has 3 functions: (1) Send spark to burner tube. (2).Open propane valve. (3) Send signal to board –burner is lit-stop sparking.  
After lockout, shut thermostat down, wait 2 minutes and repeat operation.
7. When burner ignites, board will discontinue to spark. You should feel heat within 1 minute at the ducts.
8. Set your thermostat at desired temperature.
9. To shut-down, move thermostat lever to far left and power will cease to flow to furnace. Blower will continue to run about 2 minutes until heat has left chamber.

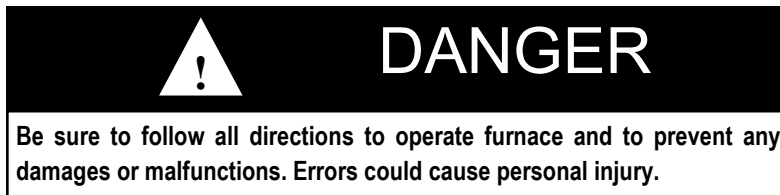

NOTE: During initial firing of this furnace, a burn-off of excess paint and oils remaining from the manufacturing process may cause "smoking" for five to ten minutes. Your selling dealer may already performed this function.

Warm air will be discharged through heat ducts or front grill on smaller units. Every furnace must have a open and uncovered return air space. Be sure area in front of grill or screen is not blocked or covered by any object.

**External Vents.** Always be sure these vents are clear of any objects like screens, duct tape, etc.

**Gas Odor.** Should you smell propane vapor in your recreational vehicle, follow these listed guidelines:

1. Evacuate all persons from the vehicle.
2. Shut off the gas supply at the propane gas container.
3. DO NOT touch any switch, phone, or radio in the vehicle.
4. Leave the entrance open for ventilation.
5. Contact a qualified RV technician or gas service technician for repairs.
6. DO NOT use or reside in the vehicle until the leak has been repaired.



## WARNING

**Do not install screens over the vents for any reason. Screens will become restrictions causing unsafe or inefficient operation.**

Gas pressure, as defined in Chapter Four - Systems, is extremely important. A dial gauge or U-tube manometer is required to perform tests and adjustments. Pressure must be set at 11 inches WC. (water column) plus or minus 1/2 inch. Incorrect gas pressure can cause any appliance to operate inconsistently and cause poor combustion. Only qualified technicians with proper equipment should make any mechanical adjustments.

Voltage must be between 10.5 volts to 13.5 volts at the furnace during operation. Below 10.5 volts the furnace will not operate as there is not enough air speed to keep sail switch open.. Both high and low voltage places excessive wear on the motor and brushes.

Any mechanical adjustments, such as electrode adjustments, should be performed by a qualified service technician.

### **COOKING SYSTEM**

All Models have a 2 burner drop-in cook top, fueled with propane. They DO NOT have a standing pilot light and must be lit with matches or hand held lighter each time you wish to use it.

#### ***Operating Instructions***

1. Know which knob controls which burner. Always be sure all burners are turned off when the stove is not in use.
2. Depress knob and turn fully counterclockwise to "LITE" position.

- a. Verify sufficient gas supply before attempting to light the burner. Air in the gas line will significantly delay burner ignition. Air in the gas lines may occur after the vehicle gas bottle and/or tank is refilled, during and after servicing other appliances on the same gas line, etc.
  - b. Do not attempt to light more than one burner at a time.
  - c. Immediately light the burner by holding a long match near the burner ports.
3. If any burner should extinguish after initial lighting or due to accidental blow out, turn gas off by turning control knob clockwise to "OFF". Wait five minutes before attempting to relight the burner. Failure to follow these instructions could result in a fire or explosion.
- If the burner should go out while cooking, or if there is an odor of gas, turn the control knob( s) clockwise to "OFF". Wait five minutes for the gas odor to disappear. If the gas odor is still present – DO NOT relight the burners. See instructions in the appliance manual.
4. To turn the burner( s) off, turn the appropriate control knob clockwise to "OFF".



## DANGER

When holding the match or lighter to ignite flame, DO NOT position your fingers close to the burner. You could get burned causing injury.



## CAUTION

Hand held igniters may be used but be sure they are the type designed for lighting open flame burners.



## WARNING

Be sure all control knobs are turned "OFF" when you are not cooking. Someone could be burned or a fire could start if a burner is accidentally left on or unattended even if only momentarily.





## CAUTION

When the recreational vehicle is not in use or while traveling, it is recommended that the gas supply also be turned off.

### **WATER HEATER**

Several energy sources are available to heat water: (1) propane gas only with manual lighting and start-up, (2) propane gas and 12 volt DC combination. A 120 volt AC option is available and may be included with either source in a combination form.



## CAUTION

Before attempting to operate any water heater, you must be sure the heater is full of water. Failure to fill with water will result in the tank warping and the element burning up.



## DANGER

If you do not follow these instructions exactly, a fire or explosion may result causing property damage, personal injury or loss of life.

### **DSI MODELS**

#### ***Operating Instructions.***

This appliance does not have a standing pilot light .A switch is located in the monitor panel for water heater operation to turn appliance 'ON or "OFF".

1. Be sure valve on propane bottle is open.
2. Turn switch on monitor panel to on.
3. Module board now takes over sending spark and also opens valve controlling propane, going to burner tube. Ignition happens for 7 seconds, it either lights or goes into lockout . Board will try 3 times before going into full lockout.

4. Wait 2 minutes and repeat procedure.
5. After heater is operating, water will reach the temperature the thermostat is preset for. Remember thermostat is non-adjustable.
6. To shut system down simply turn off switch at monitor panel.

#### ***What To Do If You Smell Gas***

- Do not try to light any appliance.
- Do not touch any electric switch.
- Do not use any phone in your recreational vehicle.
- Immediately call your gas service center from your neighbor's phone. Follow the gas service centers instructions.
- If you cannot reach your gas supplier, call the fire department.

Do not use this appliance if any part has been under water. Immediately call a qualified service technician to inspect the appliance and to replace any part of the control system and any gas control which has been under water.

Before operating the water heater, check the location of the vent to make sure it will not be blocked by the opening of any door on the trailer. Do not operate the water heater with the door open.

#### **120 VOLT AC OPTION**

Should you have 120 volt AC option there are 2 switches, One is located on outside of water heater, inside the service door. The second switch is located on the monitor panel marked as "ELECTRIC". Both switches must be in "ON POSITION" to operate the heater.

**DO NOT OPERATE THIS APPLIANCE ON TWO ENERGY SOURCES AT THE SAME TIME. DAMAGES WILL OCCUR.**

#### **Winterizing Your Water Heater**

If your water heater plumbing system is equipped with a bypass kit, use it to close off the water heater. Drain the water heater completely and leave the water heater closed off (out of the system) in the bypass position particularly if you are introducing antifreeze into the plumbing system.

Antifreeze can be very corrosive to the anode rod creating premature failure and leave sediment in the tank. If the plumbing system is not equipped with a bypass kit, and you intend to winterize by adding antifreeze to the system, remove the anode rod (storing it for the winter) and replace it with a 3/4 inch drain plug.



## CAUTION

Temperature setting on the control was factory set at the lowest setting to reduce risk of scald injury. Setting the temperature dial past the low position will increase the risk of scald injury. Children, disabled, elderly and diabetics are at highest risk of being scalded.

### REFRIGERATOR

KZ recreational vehicle installs many different sizes and models of refrigerators operating on 120 volt AC , propane, and optional 12 volt DC energy sources.

Performance of refrigerators depends on various factors, such as, energy, venting, leveling, humidity and atmospheric heat temperatures, but not limited to these. All refrigerators are designed and built with absorption type of cooling units requiring careful leveling and venting conditions. This appliance uses heat to make cold conditions.

#### **Leveling**

For correct operation, the refrigerator must be within three degrees of level in any direction. Continued operation outside of these limits will result in irreparable damage to the cooling unit in the refrigerator. Stay within 1 degree for best results.

#### **Venting**

For an absorption unit to operate fully it must have two vents. One vent is on the roof or sidewall at the upper end of the refrigerator, and a second vent is a lower service vent door at the lower area of the refrigerator.

#### **Door Seal**

To maintain cooling efficiency the door must seal completely on all four sides along the door gaskets. Frequent frost build up or reduced cooling are indicators of air leaks around the doors. Place a strip of paper the size of a dollar bill between the flange and door gasket. Close the door and pull the paper out. There should be a light frictional drag indicating proper seal. Should the paper feel loose, the gasket is not sealing well. Contact your dealer or service center.

### **Door Latch**

A positive or full locking latch is not permitted through codes. Each latch has a rating by pounds of pressure, yet will prevent the door from opening during travel.

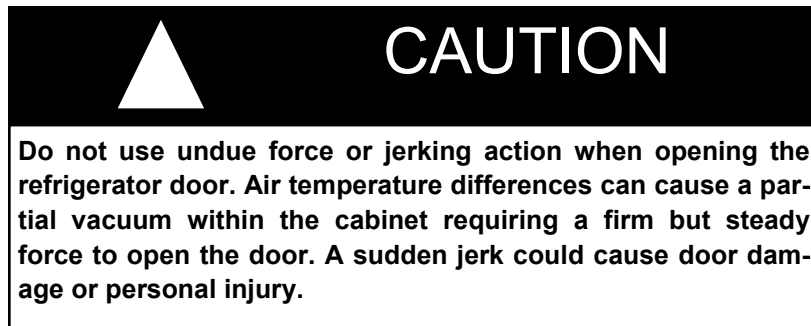

### **Operation for Refrigerators**

With each refrigerator comes a owners manual. Read and understand the information. Follow the operation instructions using controls to start and operate the appliance during prep time and camping use.

Read and use it to keep you well informed on all features, operation, maintenance, and cleaning procedures for long life.

### **Operation during Travel**

During travel over road camper will not be level how ever the chemicals in cooling unit will also be moving preventing any problems. Keep the door shut to retain cold temperature during travel.

### **AIR CONDITIONER —OPTIONAL**

Normal air conditioner is built into sidewall, near roof line and will be installed only by factory trained production personnel. It is rated at 8000 BTU in put and draws 7.1 amps.

This air conditioner operates with 120 volt AC power only LO or HI voltage will effect performance and durability of this unit.

To operate use either buttons on air conditioner or remote control as supplied with appliance.

Additional instructions are included with each appliance , supplied and written by the manufacturer of air conditioner.  
Coaches built and shipped to dealer with out side air conditioner will have roof constructed to accept 13,500 BTU roof mounted unit .  
These require more amps of power for full performance. See their operating instructions more information

### **Monitor panel**

This panel gives you information as to the liquid level of all your tanks holding water fresh or waste by pressing a button for each tank separately.

Secondly it has a switch to turn on (a) Water pump, (b) Water heater ( C) Electric option portion of water heater.

### **TENTS**

All tents have a "C" channel sewn onto fabric and channel is installed onto aluminum extrusions of door and its frame. Six pieces of separate extrusions, 3 on door and 3 on door frame will hold tent from coming loose. They also prevent anyone from falling out onto the ground.

Bunk doors have weight rating of 1100 pounds limitation per door.

The tent (s) on your camping trailer are manufactured with mostly vinyl and polyester fabric laminated to vinyl. Since this material can't breath, you may, depending on weather conditions, temperature variance, and furnace usage, experience some condensation inside of coach, more so at night than day. Such condensation can be reduced or possibly eliminated by opening the upper corner of bunk end panel, 1/2" to 1". Fold over to allow small quantity of air to move across roof panel at the end which has head of sleeping person.

Each tent has bed bow mounted onto the bunk door which will swing into upright position. A bow brace is also supplied to support the bow. It slips onto round peg mounted onto bow and inner end onto bracket mounted to upper wall inside.

Two cables are preinstalled from door to sidewall holding door in horizontal opposition

### **Important information on your tent**

Two tendencies that you may discover in any tent assembly are condensation and possible minor leakage on first several times

used. The first one is condensation, described above and in previous chapter. The second is concerning potential leakage.

Prepare for your first camping trip:

- Set up unit at home to become familiar with method of setup.
- Spray outside of unit with water until thoroughly wet. Allow unit to dry completely. Repeat wet and dry process twice more. This will cause material fibers to close up and threads to swell sealing your unit and therefore preventing leakage.
- Always allow tent to dry completely with bows and braces in place. Storing unit wet promotes mold and mildew and is not an item that is considered warrantable.

ALL VINYL TENTS NEED TO GET WET ONE OR MORE TIMES TO SEAL THE NEEDLE HOLES. Your tent may leak the first time it gets wet. Do not be alarmed. The tent is sewn with special thread that swells up and seals the needle holes after it has been wet. Rubbing a wax candle over sewn seams after the first rain may also assist in quicker sealing.

It is suggested to set up your camper and spray water over tent portion at least two times before using camper the first time for 30 minutes each time fully set up. Allow it to dry with all bows and braces in position. This is called preconditioning. Your dealer may have performed this for you.

Prevent Leakage During Use

- Do not rub against walls, roof or canvas windows when wet or when raining.
- Do not place objects against tent walls.
- Do not over extend or over stretch your tent, such as pillows.
- Do not spray insect repellent or hair spray on fabric as these items may destroy water repellency of this fabric
- Do not put tent away in wet conditions. This might be difficult when leaving campsite in raining conditions. If this does occur, within 24 hours be sure to open tents, set up completely for the tents to dry out to prevent any possibility of mildew to start.

ALWAYS VENTILATE AND DRY THE TENT WITH BOWS AND BRACES IN PLACE as soon as possible after each exposure to moisture. Mildew is always the result of negligence.

The plastic windows have a -20° cold crack rating. Do not raise the tent up to maximum height in extreme cold (0 degree) weather as the windows may shatter.

### **CLEAING YOUR TENT**

- To clean your tent, brush dry with soft bristle brush, or use clean tap water with soft brush, or wash with tap water from hose using spray nozzle. If the fabric had been exposed to salt water, wash with hose using tap water.
- Do not use solvents, soaps or detergents. Do not use aerosol cleaners. If insect repellent is used around the fabric, do not use spray directly on the fabric. An agent used in most sprays, as a propellant, will damage or destroy water repellent finishes (hair sprays, insect sprays, deodorants, etc.) DO NOT touch your canvas while it is raining. It will wick through and appear to make it leak.
- If you have stains or have a certain problem, contact your dealer so he can get back with us before trying solvents that might damage your unit.
- Clean vinyl ends with automotive vinyl cleaner.

### **TENT SHRINKAGE**

All canvas products will shrink when wet. To prevent the shrinkage from damaging the tent, such as pulling seams, loops and material, reduce frame tension when canvas is wet. Readjust to normal tension when dry. Canvas should not be stretched completely taut or left under constant tension as damage to the tent may occur.